

جي جي سي

G G C

شركة الخليج لفتحات التكييف المركزي  
GULF GRILLES CO.

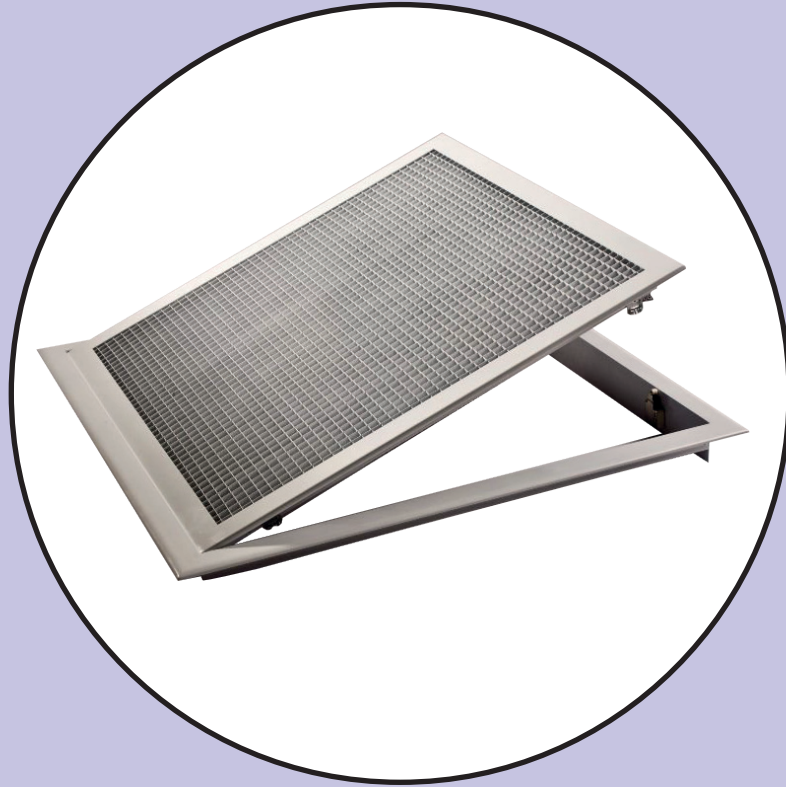

ACCESS DOORS

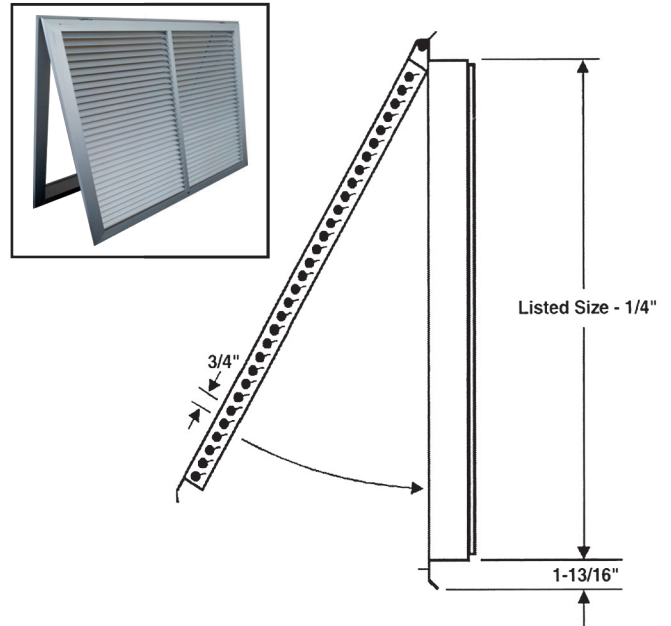

### PRODUCT DESCRIPTION

- The frame and blades are extruded aluminium alloy and are polyester powder coated with a white finish.
- The frame has a typical wall thickness of 1/16" and is separated from the blades by an extruded rigid PVC track which becomes an integral part of the frame.
- This method of assembly helps to eliminate corrosion and vibration.
- All blades are airfoil in design, are set in a fixed position at an angle of 45° and are spaced 3/4" on center.
- The blade or frame section is secured to an extruded aluminium frame with two hinges and a locking nut arrangement.
- This allows the frame or blade assembly to swing away for access to the area behind as desired.
- Air filters for use with access doors are available.
- As an option to provide for 1" thick air filter the model is assembled in a two part system. One is the mounting frame that serves as a retainer for the filter and the other is the core which provides access to the filter.
- Standard finish is white for frame and blades. Painted under electrostatic polyester powder coated system. Other colors available on request. The polyester powder of highest quality are used to enhance the appearance of the units.

### Listed Sizes

Size	Horizontal		Vertical		CFM Range
	in.	(mm)	in.	(mm)	
10 x 6	10	(254.0)	6	(152.4)	60 - 100
10 x 8	10	(254.0)	8	(203.2)	80 - 140
12 x 6	12	(304.8)	6	(152.4)	70 - 120
12 x 8	12	(304.8)	8	(203.2)	100 - 200
12 x 12	12	(304.8)	12	(304.8)	185 - 295
18 x 6	18	(457.2)	6	(152.4)	105 - 210
18 x 12	18	(457.2)	12	(304.8)	110 - 215
18 x 18	18	(457.2)	18	(457.2)	250 - 500
24 x 12	24	(609.6)	12	(304.8)	370 - 665
24 x 18	24	(609.6)	18	(457.2)	340 - 565

Size	Horizontal		Vertical		CFM Range
	in.	(mm)	in.	(mm)	
24 x 24	24	(609.6)	24	(609.6)	455 - 1065
30 x 12	30	(762.0)	12	(304.8)	470 - 845
30 x 18	30	(762.0)	18	(457.2)	280 - 700
30 x 24	30	(762.0)	24	(609.6)	580 - 1160
36 x 18	36	(914.4)	18	(457.2)	855 - 1370
36 x 24	36	(914.4)	24	(609.6)	915 - 1830
36 x 30	36	(914.4)	30	(762.0)	1440 - 2305
48 x 24	48	(1219.2)	24	(609.6)	1530 - 2755
48 x 30	48	(1219.2)	30	(762.0)	1540 - 3080
48 x 36	48	(1219.2)	36	(914.4)	1850 - 3240

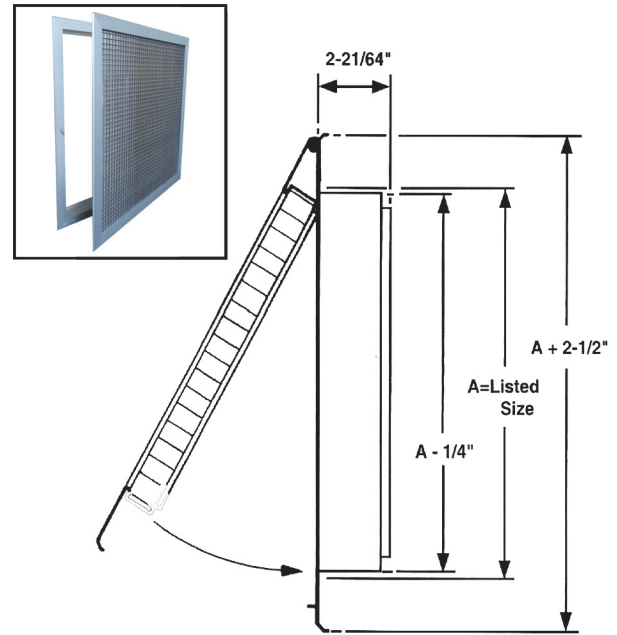
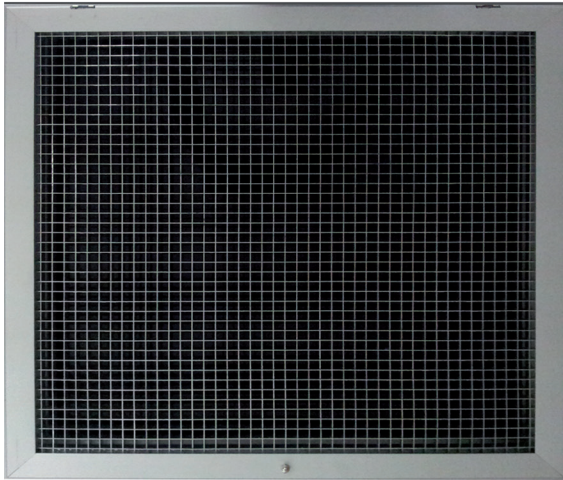

### PRODUCT DESCRIPTION

- The frame is extruded aluminium alloy and is polyester powder coated with a white finish.

The frame has a typical wall thickness of 1/16" .

- The grid cores are all aluminium, 1/32" thick in two grid sizes, mechanically locked in margins : 1/2" x 1/2" x 1/2" and 1" x 1" x 1/2" with a 90% free area.
- The grid core/frame section is secured to an extruded aluminium frame with two hinges and a locking nut arrangement.
- This allows the frame/grid assembly to swing away for access to the area behind as desired.

- The frame holds 1" thick air filter behind grille face. As an option to provide the filter.

- The model is assembled in a two part system. One is the mounting frame that serves as a retainer for the filter and the other is the grid which provides access to the filter.

- Standard finish is white for frame and grid cores. Painted under electrostatic polyester powder coated system. Other colors available on request. The polyester powder of highest quality are used to enhance the appearance of the units.

### Listed Sizes

Size	Horizontal		Vertical		CFM Range
	in.	(mm)	in.	(mm)	
10 x 6	10	(254.0)	6	(152.4)	90 - 250
10 x 8	10	(254.0)	8	(203.2)	130 - 350
12 x 6	12	(304.8)	6	(152.4)	115 - 310
12 x 8	12	(304.8)	8	(203.2)	160 - 475
12 x 12	12	(304.8)	12	(304.8)	330 - 745
18 x 6	18	(457.2)	6	(152.4)	180 - 530
18 x 12	18	(457.2)	12	(304.8)	255 - 640
18 x 18	18	(457.2)	18	(457.2)	395 - 1380
24 x 12	24	(609.6)	12	(304.8)	690 - 1730
24 x 18	24	(609.6)	18	(457.2)	530 - 1595

Size	Horizontal		Vertical		CFM Range
	in.	(mm)	in.	(mm)	
24 x 24	24	(609.6)	24	(609.6)	720 - 2875
30 x 12	30	(762.0)	12	(304.8)	885 - 2215
30 x 18	30	(762.0)	18	(457.2)	685 - 2055
30 x 24	30	(762.0)	24	(609.6)	925 - 3240
36 x 18	36	(914.4)	18	(457.2)	1620 - 3640
36 x 24	36	(914.4)	24	(609.6)	1635 - 4910
36 x 30	36	(914.4)	30	(762.0)	2820 - 6344
48 x 24	48	(1219.2)	24	(609.6)	2932 - 7330
48 x 30	48	(1219.2)	30	(762.0)	2810 - 8430
48 x 36	48	(1219.2)	36	(914.4)	3340 - 8905

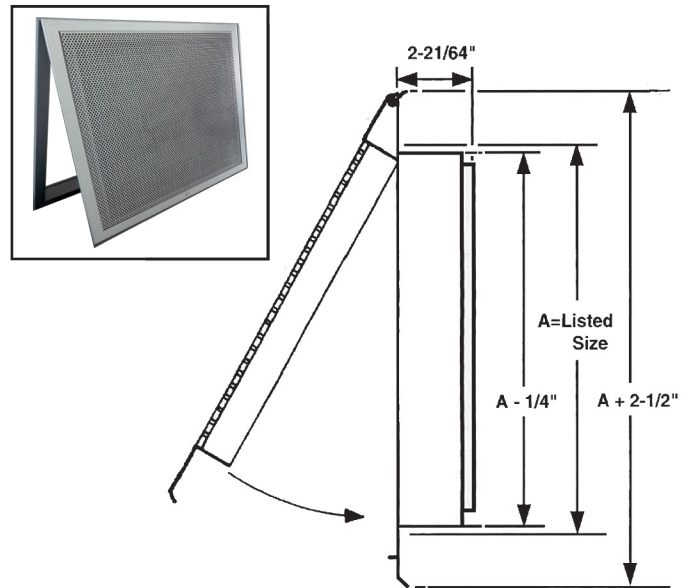
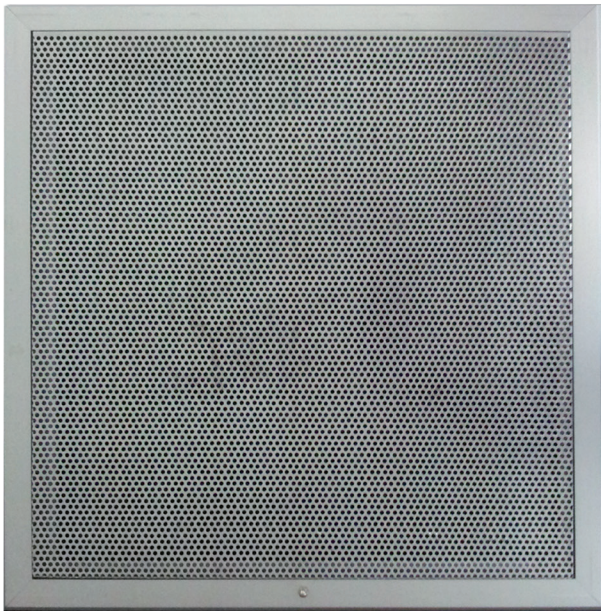

### PRODUCT DESCRIPTION

- The frame is extruded aluminium alloy and is polyester powder coated with a white finish.
- The frame has a typical wall thickness of 1/16" .
- The perforated face is made of white powder coated aluminum sheet 5/32" diameter holes a pitch of 15/64", 60° staggered and 45% of its face open.
- The perforated face/frame section is secured to an extruded aluminium frame with two hinges and a locking nut arrangement.
- This allows the frame/perforated assembly to swing away for access to the area behind as desired.
- The frame holds 1" thick air filter behind grille face. As an option to provide the filter.
- The model is assembled in a two part system. One is the mounting frame that serves as a retainer for the filter and the other is the core which provides access to the filter.
- Standard finish is white for frame and perforated face. Painted under electrostatic polyester powder coated system. Other colors available on request. The polyester powder of highest quality are used to enhance the appearance of the units.

### Listed Sizes

Dimensions					
Size	Horizontal		Vertical		CFM Range
	in.	(mm)	in.	(mm)	
10 x 6	10	(254.0)	6	(152.4)	100 - 200
10 x 8	10	(254.0)	8	(203.2)	140 - 275
12 x 6	12	(304.8)	6	(152.4)	125 - 250
12 x 8	12	(304.8)	8	(203.2)	180 - 360
12 x 12	12	(304.8)	12	(304.8)	350 - 615
18 x 6	18	(457.2)	6	(152.4)	190 - 440
18 x 12	18	(457.2)	12	(304.8)	270 - 535
18 x 18	18	(457.2)	18	(457.2)	415 - 1040
24 x 12	24	(609.6)	12	(304.8)	730 - 1455
24 x 18	24	(609.6)	18	(457.2)	555 - 1110

Dimensions					
Size	Horizontal		Vertical		CFM Range
	in.	(mm)	in.	(mm)	
24 x 24	24	(609.6)	24	(609.6)	750 - 2250
30 x 12	30	(762.0)	12	(304.8)	915 - 1830
30 x 18	30	(762.0)	18	(457.2)	700 - 1400
30 x 24	30	(762.0)	24	(609.6)	945 - 2830
36 x 18	36	(914.4)	18	(457.2)	1690 - 2955
36 x 24	36	(914.4)	24	(609.6)	2275 - 3980
36 x 30	36	(914.4)	30	(762.0)	2865 - 5010
48 x 24	48	(1219.2)	24	(609.6)	3050 - 6100
48 x 30	48	(1219.2)	30	(762.0)	3840 - 7680
48 x 36	48	(1219.2)	36	(914.4)	4625 - 9250

## ACCESS DOORS WITH FIXED BLADES PERFORMANCE DATA

### MODEL : AF2 - X

Listed Sizes (inches)	Area Factor (Sq. ft.)	45° Blade Angle							
		Face Velocity (fpm)							
		200	300	400	500	600	700	800	900
		Static Pressure Drop (in. w. g.)							
		0.004	0.008	0.015	0.023	0.032	0.044	0.056	0.071
Air Capacity (cfm)									
10 x 6	0.143			57	72	86	100		
10 x 8	0.20			80	100	120	140		
12 x 6	0.17			68	85	102	119		
12 x 8	0.25			100	125	150	175	200	
12 x 12	0.37				185	222	259	296	
18 x 6	0.26			104	130	156	182	208	
18 x 12	0.54	108	162	216					
18 x 18	0.83		249	332	415	498			
24 x 12	0.74				370	444	518	592	666
24 x 18	1.13		339	452	565				
24 x 24	1.52		456	608	760	912	1064		
30 x 12	0.94				470	564	658	752	846
30 x 18	1.40	280	420	560	700				
30 x 24	1.93		579	772	965	1158			
36 x 18	1.71				855	1026	1197	1368	
36 x 24	2.29			916	1145	1374	1603	1832	
36 x 30	2.88				1440	1728	2016	2304	
48 x 24	3.06				1530	1836	2142	2448	2754
48 x 30	3.85			1540	1925	2310	2695	3080	
48 x 36	4.63			1852	2315	2778	3241		

Note : Determine CFM by the following equation :

$$\text{CFM} = \text{Area Factor} \times \text{Face Velocity.}$$

To calculate the approximate area factor of sizes not shown, use the following formula.

$$\text{Area Factor} = \frac{\text{Length} [0.375 + (N \times 0.3125)]}{144}$$

Where: Length = Nominal width - 0.875 - (\*number of dividers x 0.625)

\*Based upon dividers spaced every 12 inches.

$$N = \frac{\text{Height} - 1.5}{0.75}$$

Access door with 0° blades will have a lower static pressure with the same face velocity.

## ACCESS DOORS WITH EGG CRATE PERFORMANCE DATA

MODEL : AC2 - X

Listed Sizes (inches)	Core Area (Sq. ft.)	Core Velocity (fpm)								
		200	300	400	500	600	700	800	900	1000
		Static Pressure Drop (in. w. g.)								
		0.010	0.016	0.026	0.042	0.059	0.082	0.106	0.130	0.165
10 x 6	0.312		93	125	156	187	218	250		
10 x 8	0.441		132	176	220	264	309	353		
12 x 6	0.387		116	155	194	232	271	310		
12 x 8	0.527		158	211	264	316	369	422	474	
12 x 12	0.829			332	414	497	580	663	746	
18 x 6	0.592		178	237	296	355	414	474	533	
18 x 12	1.281	256	384	512	640					
18 x 18	1.970	394	591	788	985	1182	1379			
24 x 12	1.733			693	866	1039	1213	1386	1560	1733
24 x 18	2.659	532	798	1064	1330	1595				
24 x 24	3.595	719	1078	1438	1797	2157	2516	2876		
30 x 12	2.215			886	1108	1329	1550	1772	1994	2215
30 x 18	3.424	685	1027	1370	1712	2054				
30 x 24	4.632	926	1390	1853	2316	2779	3242			
36 x 18	4.047			1619	2023	2428	2833	3238	3642	
36 x 24	5.457		1637	2183	2728	3274	3820	4365	4911	
36 x 30	7.049			2820	3525	4229	4934	5639	6344	
48 x 24	7.330			2932	3665	4398	5131	5864	6597	7330
48 x 30	9.365		2810	3746	4683	5619	6555	7492	8428	
48 x 36	11.130		3339	4452	5565	6678	7791	8904		

Note : Determine CFM by the following equation :

$$\text{CFM} = \text{Core Area} \times \text{Core Velocity}$$

For sizes not shown, the approximate core area in square feet can be calculated by using the following formula.

$$\text{Core Area} = \frac{(\text{Nominal Length} - 1) (\text{Nominal width} - 1)}{144}$$

## ACCESS DOORS WITH FIXED BLADES PERFORMANCE DATA

### MODEL : AP2 - X

Listed Sizes (Inches)	Core Area (Sq. ft.)	Core Velocity (fpm)						
		200	300	400	500	600	700	800
		Static Pressure Drop (in. w.g.)						
		0.012	0.032	0.055	0.087	0.123	0.170	0.221
Air Capacity (cfm)								
10 x 6	0.34		102	136	170	204		
10 x 8	0.46		138	184	230	276		
12 x 6	0.41		123	164	205	246		
12 x 8	0.60		180	240	300	360		
12 x 12	0.88			352	440	528	616	
18 x 6	0.63		189	252	315	378	441	
18 x 12	1.34	268	402	536				
18 x 18	2.08	416	624	832	1040			
24 x 12	1.82			728	910	1092	1274	1456
24 x 18	2.78	556	834	1112				
24 x 24	3.75	750	1125	1500	1875	2250		
30 x 12	2.29			916	1145	1374	1603	1832
30 x 18	3.50	700	1050	1400				
30 x 24	4.72	944	1416	1888	2360	2832		
36 x 18	4.22			1688	2110	2532	2954	
36 x 24	5.69			2276	2845	3414	3983	
36 x 30	7.16			2864	3580	4296	5012	
48 x 24	7.63			3052	3815	4578	5341	6104
48 x 30	9.60			3839	4799	5759	6719	7678
48 x 36	11.57			4624	5783	6940	8096	9253

Note : Determine CFM by the following equation :

$$\text{CFM} = \text{Core Area} \times \text{Core Velocity}$$

For sizes not shown, the approximate core area in square feet can be calculated by using the following formula.

$$\text{Core Area} = \frac{(\text{Nominal Length} - 3/4)(\text{Nominal Width} - 3/4)}{144}$$

# INSTALLATION DETAILS

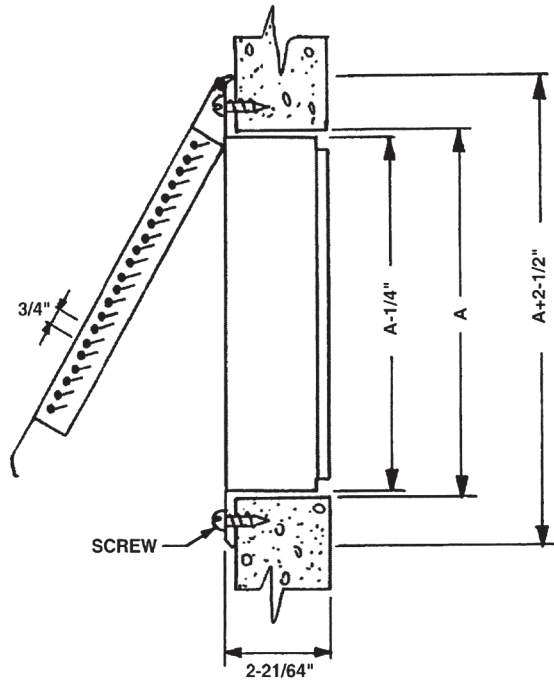

**ACCESS DOOR WITH FIXED HORIZONTAL BLADES**

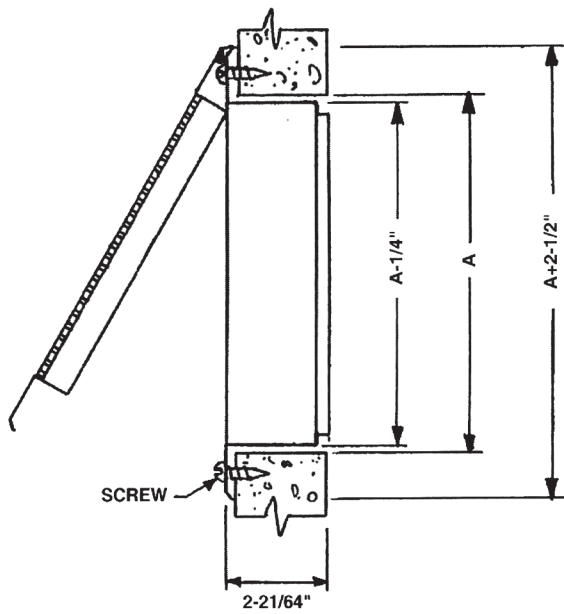

**ACCESS DOOR WITH PERFORATED**

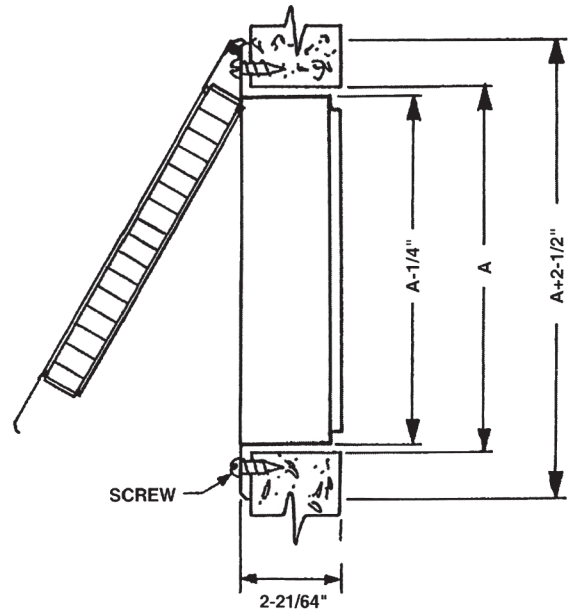

**ACCESS DOOR WITH EGG CRATE**

A = LISTED SIZE