

جي جي سي

G G C

شركة الخليج لفتحات التكييف المركزي

GULF GRILLES CO.

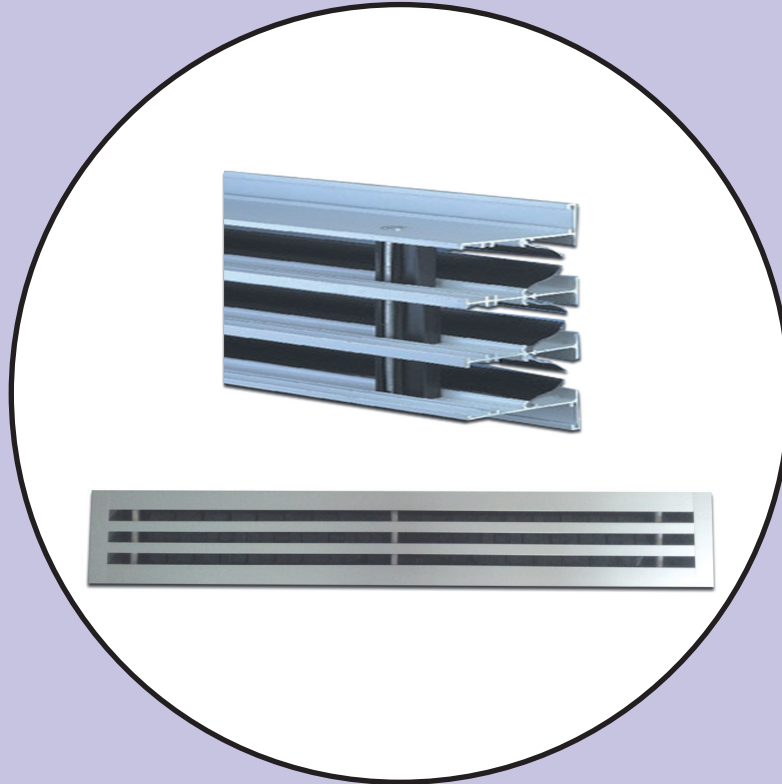

LINEAR
SLOT DIFFUSER

A07 LINEAR
SLOT DIFFUSER

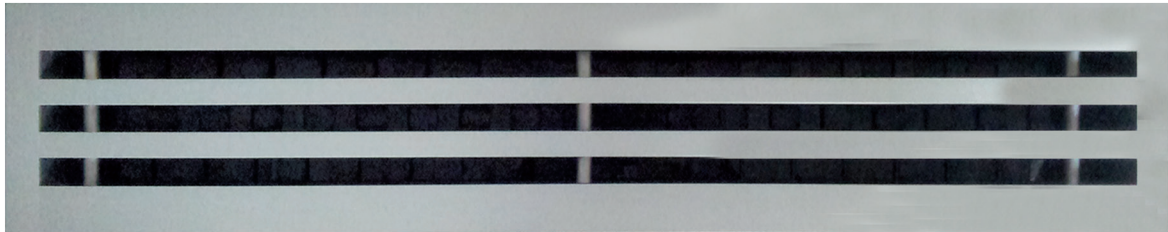
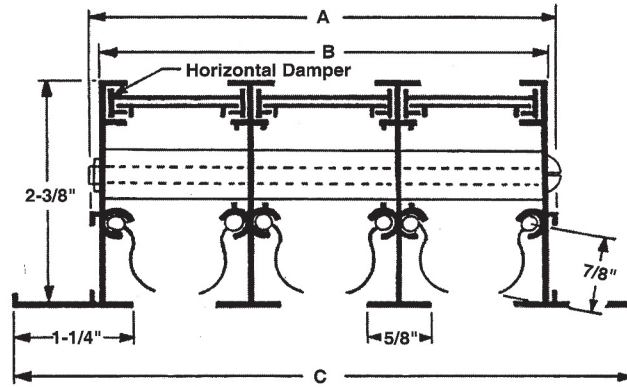

PRODUCT DESCRIPTION

- The linear slot diffuser with deflection blades and control damper is constructed of extruded aluminium alloy and are polyester powder coated finish.
- The fully adjustable deflection blades allow for the air pattern to be controlled along the ceiling, straight down or at some intermediate setting.
- The deflecting blades are designed so that when in the closed position, the air pressure tends to form a tight seal.
- The slots are available in 3/4" or 1" width.
- The air flow rate can be varied without changing the air pattern by the use of the volume control damper attached to the rear side of the diffuser.
- The volume control damper consists of two strips of extruded aluminium, one fixed and one movable.
- They both have 5/8" x 7/8" rectangular holes on 1-3/4" center, for 3/4" and 1" slot opening.
- By offsetting the holes the air flow rate can be reduced.
- Damper works also as equalizing grid.
- Maximum length supplied - 10 feet.
- Standard finish is white color for slot diffuser and deflection blades. Damper in black color. Painted under electrostatic polyester powder coated system. Other colors available on request. The polyester powder of highest quality are used to enhance the appearance of the units.

Listed Sizes

3/4" Slot Width

No. of Slots	1	2	3	4	5	6	7	8
A (in.)	1.65	2.99	4.33	5.67	7.01	8.35	9.65	10.94
B (in.)	1.42	2.76	4.09	5.43	6.81	8.15	9.41	10.71
C (in.)	3.31	4.61	5.94	7.28	8.58	9.96	11.38	12.64
CFM/FT.	10-100	20-125	30-150	40-200	50-250	60-300	70-350	80-400

1" Slot Width

No. of Slots	1	2	3	4	5	6	7	8
A (in.)	1.94	3.58	5.23	6.88	8.52	10.17	11.81	13.46
B (in.)	1.70	3.35	4.99	6.64	8.28	9.93	11.58	13.22
C (in.)	3.48	5.13	6.77	8.42	10.06	11.71	13.36	15.00
CFM/FT.	10-100	20-125	30-150	40-200	50-250	60-300	70-350	80-400

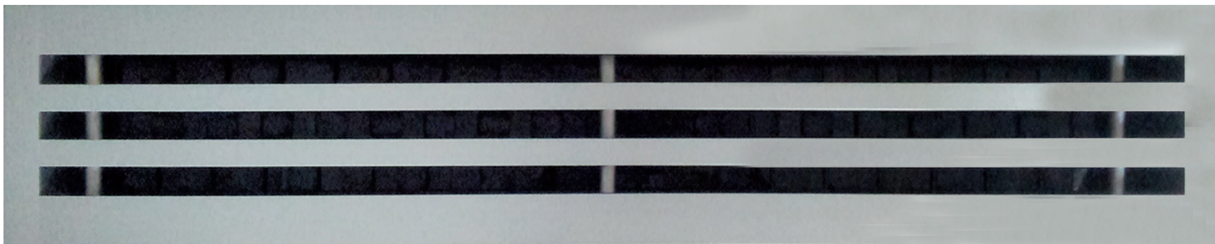
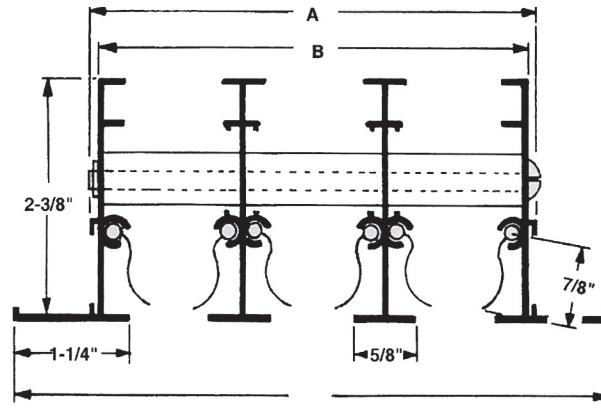

PRODUCT DESCRIPTION

- The linear slot diffuser with deflection blades is constructed of extruded aluminium alloy and are polyester powder coated finish.
- The fully adjustable deflection blades allow for the air pattern to be controlled along the ceiling, straight down or at some intermediate setting.
- The deflecting blades are designed so that when in the closed position, the air pressure tends to form a tight seal.
- The slots are available in 3/4" or 1" width.
- Maximum length supplied - 10 feet.
- Standard finish is white color for slot diffuser and deflection blades. Painted under electrostatic polyester powder coated system. Other colors available on request. The polyester powder of highest quality are used to enhance the appearance of the units.

Listed Sizes

3/4" Slot Width

No. of Slots	1	2	3	4	5	6	7	8
A (in.)	1.65	2.99	4.33	5.67	7.01	8.35	9.65	10.94
B (in.)	1.42	2.76	4.09	5.43	6.81	8.15	9.41	10.71
C (in.)	3.31	4.61	5.94	7.28	8.58	9.96	11.38	12.64
CFM/ft.	10-100	20-125	30-150	40-200	50-250	60-300	70-350	80-400

1" Slot Width

No. of Slots	1	2	3	4	5	6	7	8
A (in.)	1.94	3.58	5.23	6.88	8.52	10.17	11.81	13.46
B (in.)	1.70	3.35	4.99	6.64	8.28	9.93	11.58	13.22
C (in.)	3.48	5.13	6.77	8.42	10.06	11.71	13.36	15.00
CFM/ft.	10-100	20-125	30-150	40-200	50-250	60-300	70-350	80-400

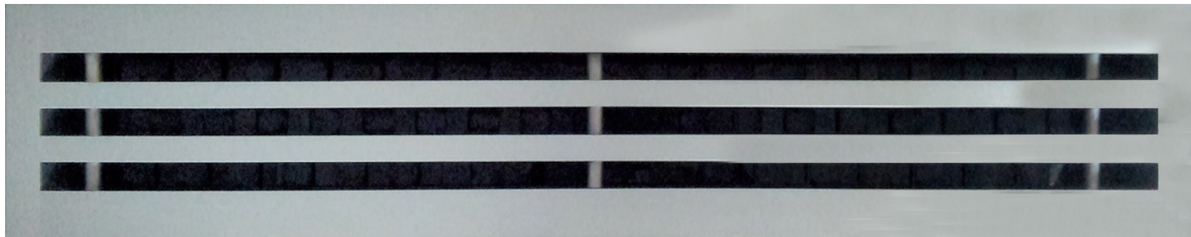
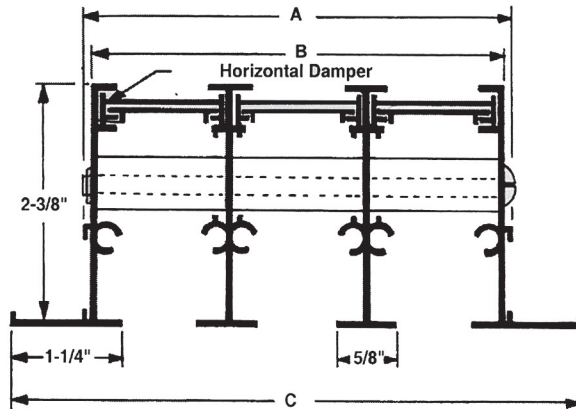

PRODUCT DESCRIPTION

- The linear slot diffuser with volume control damper and no deflection blades is constructed of extruded aluminium alloy and are polyester powder coated finish.
- The air flow rate can be varied by the use of the volume control damper attached to the rear side of the diffuser.
- The volume control damper consists of two strips of extruded aluminium, one fixed and one movable.
- They both have a series of 5/8" x 7/8" rectangular holes on 1-3/4" center, for 3/4" and 1" slot opening.
- By offsetting the holes the air flow rate can be reduced.
- Maximum length supplied - 10 feet.
- Standard finish is white color for slot diffuser. Damper in black color. Painted under electrostatic polyester powder coated system. Other colors available on request. The polyester powder of highest quality are used to enhance the appearance of the units.

Listed Sizes

3/4" Slot Width

No. of Slots	1	2	3	4	5	6	7	8
A (in.)	1.65	2.99	4.33	5.67	7.01	8.35	9.65	10.94
B (in.)	1.42	2.76	4.09	5.43	6.81	8.15	9.41	10.71
C (in.)	3.31	4.61	5.94	7.28	8.58	9.96	11.38	12.64
CFM/FT.	10-100	20-125	30-150	40-200	50-250	60-300	70-350	80-400

1" Slot Width

No. of Slots	1	2	3	4	5	6	7	8
A (in.)	1.94	3.58	5.23	6.88	8.52	10.17	11.81	13.46
B (in.)	1.70	3.35	4.99	6.64	8.28	9.93	11.58	13.22
C (in.)	3.48	5.13	6.77	8.42	10.06	11.71	13.36	15.00
CFM/FT.	10-100	20-125	30-150	40-200	50-250	60-300	70-350	80-400

END CAP ARRANGEMENTS

SLOT DIFFUSER WITHOUT END CAP

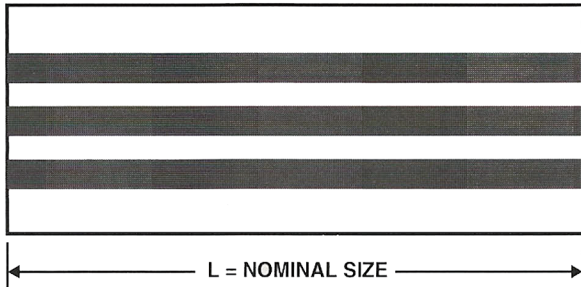

SLOT DIFFUSER WITH ONE END CAP : RIGHT OR LEFT

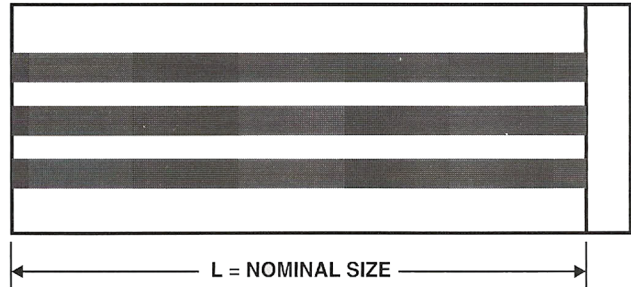

END CAP BOTH ENDS

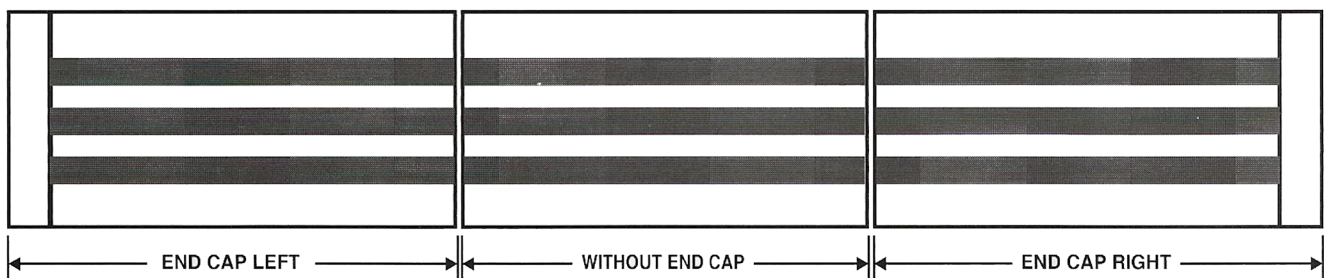
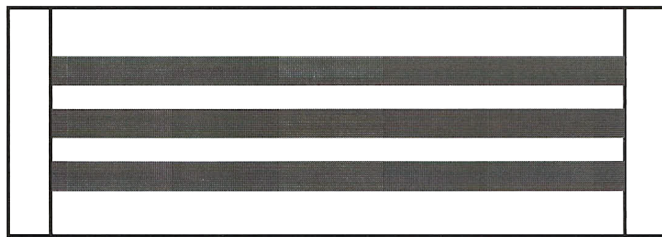

Linear Slot Supply Diffuser Featuring Fully Adjustable Deflection Blades. The Deflection Blades Provide Combination Air-Pattern, Flow Rate Control and Blank-Off.

Single Slot Adjustments

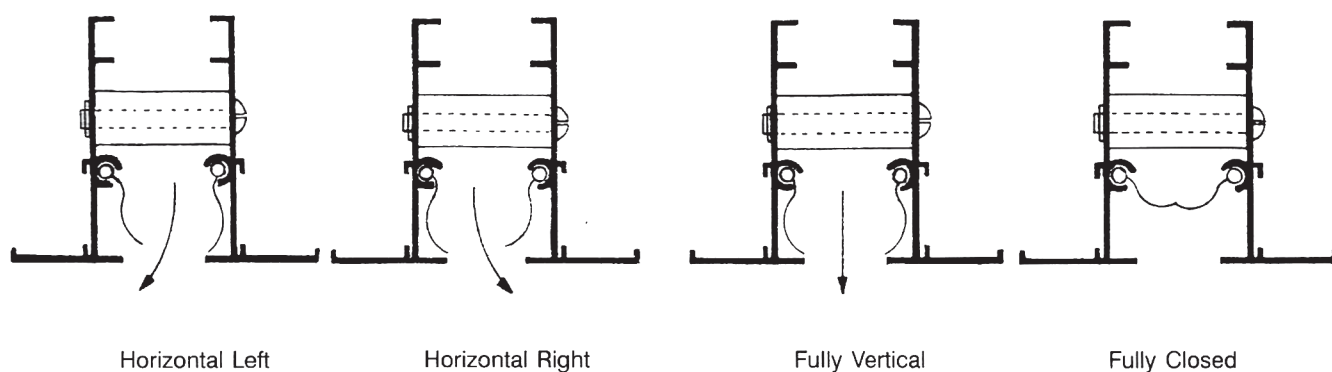

Multiple Slot Adjustments, Up to 8 Slots Wide

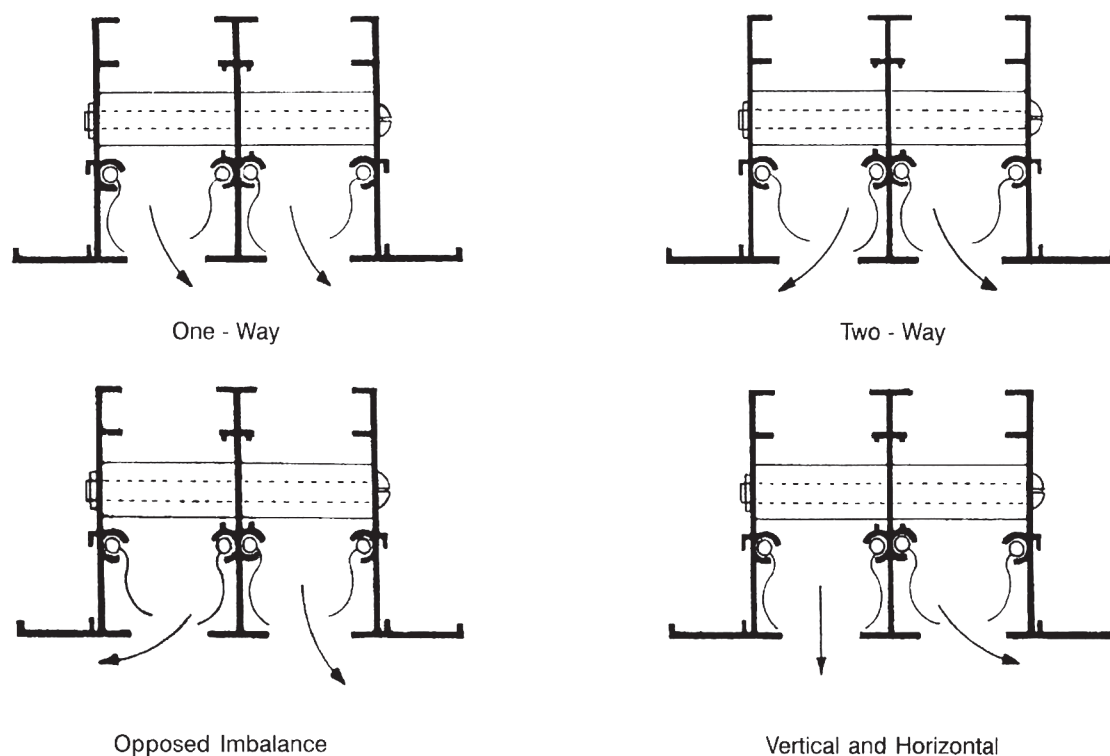

IMPORTANT NOTE :

In all air-slot type diffusers, constriction of free area by blade relationships must be set carefully so as not to throttle airstream, with resultant increase in static pressure and noise level criteria. It is recommended that care be exercised in setting blades to prevent such excessive constriction of air passageway.

2-Way throw may be obtained by staggering each length of deflection blades alternately from right to left.

MITERED CORNERS

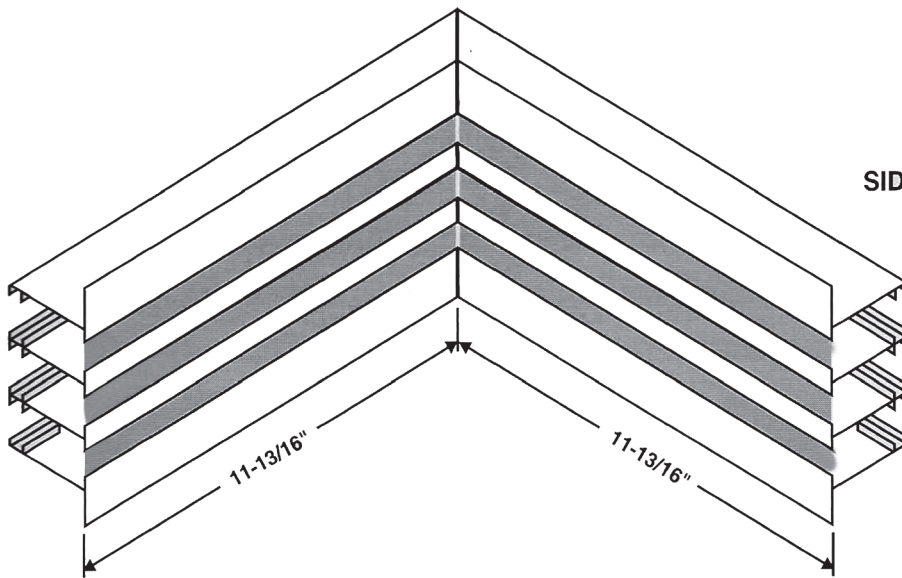

SIDE WALL - INSIDE CORNER

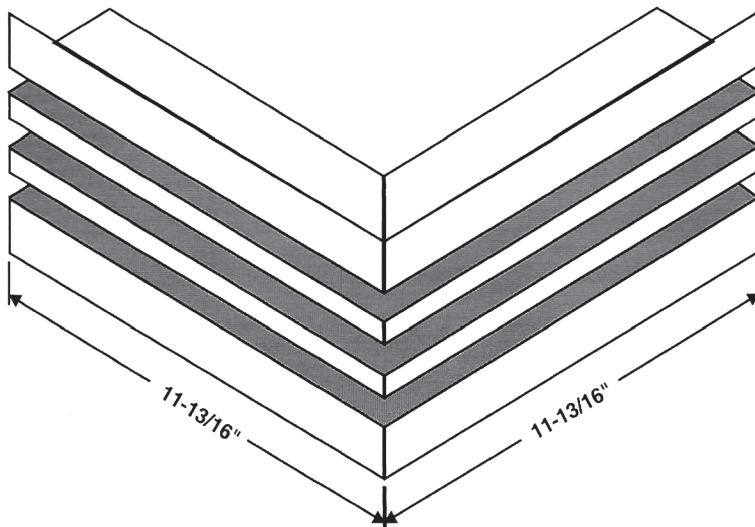

SIDE WALL - OUTSIDE CORNER

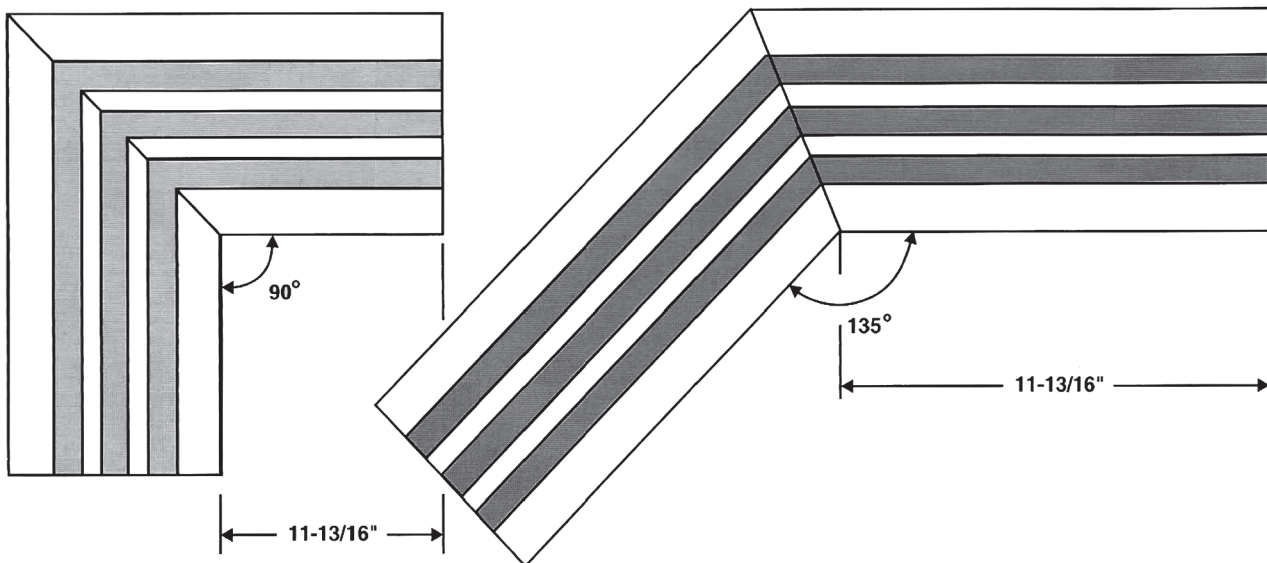

CEILING CORNER PIECES (Available in one through eight slots)

LINEAR SLOT AIR DIFFUSERS ENGINEERING DATA

Blade Settings -

The deflection blades of the supply slot linear diffuser can be adjusted to give either a horizontal or vertical air pattern. The horizontal air flow adjustment may be set for either left or right hand throw.

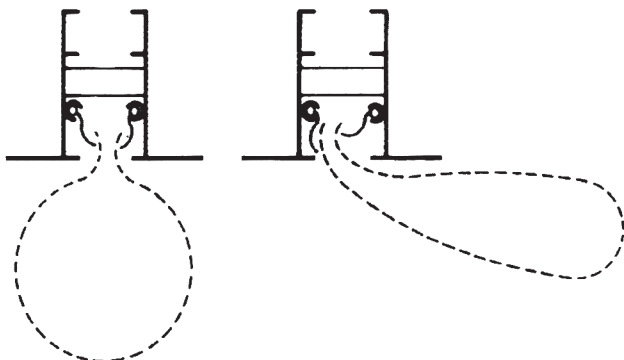

Changing the blade setting also changes the noise and total pressure.

Throw Data -

All throw data is based on the results of tests of 4-foot length diffusers. To determine throws for other diffuser lengths, use correction factors as follows:

Diffuser Active Length(ft.)	1	2	3	4	6-8
Throw Correction Factor	0.6	0.8	0.9	1.0	1.3

Sound Data -

Sound data (NC values) shown in the Performance Tables are based on a room absorption of 10dB, re 10⁻¹² Watts and a 4-foot unit test length. To determine NC values for other lengths, add NC value to catalog data as follows :

Diffuser Active Length (ft.)	2	3	4	5	6-8
Add NC Value (dB)	-3.0	-1.5	0	1.0	2.0

Selection Procedure

The horizontal throw data is presented in the performance data pages with all slots supplying air in a given direction. To determine two-way throw, use the catalog throw data for the desired quantity of air from the number of slots in each direction and reduce the throw by twenty percent.

Example

Determine the throw for an LS3-AD (3/4" Slot Width) 2 ft. long, 3-slot diffuser with 250 CFM in one direction and 120 CFM in the other.

- A. 250 CFM, 2', 2-slots = 125 CFM/ft
Catalog throws = 31 - 37
Throws x 0.80 = 25 - 30
- B. 120 CFM, 2', 1-slot = 60 CFM/ft
Catalog throws = 22 - 26
Throw x 0.80 = 18 - 21

Area Factor Summary

Slot Width	Number of Slots	Horizontal	Vertical	Return
3/4"	1	0.073	0.121	0.123
	2	0.135	0.180	0.184
	3	0.201	0.237	0.242
	4	0.265	0.295	0.301
	5	0.330	0.355	0.362
	6	0.395	0.413	0.421
	7	0.455	0.470	0.479
	8	0.520	0.530	0.539
1"	1	0.088	0.184	0.188
	2	0.162	0.274	0.281
	3	0.241	0.360	0.367
	4	0.318	0.448	0.457
	5	0.396	0.540	0.551
	6	0.474	0.628	0.641
	7	0.546	0.714	0.732
	8	0.631	0.806	0.822



SUPPLY LINEAR SLOT AIR DIFFUSERS PERFORMANCE DATA

**Model : LS3 - AD
Linear Diffuser 3/4" Slot Width**

No. of Slots	CFM/FT.	10	20	30	40	50	60	70	80	90	100	125	150	200	250	300	350	400	
1	HOR. SP	.022	.089	.200	.356	.557	.802	1.092	1.426	1.804	2.228								
	THROW	7-10	13-15	15-19	18-21	20-24	22-26	23-28	25-30	27-32	28-33								
	NC	<20	<20	30	39	41	47	>50	>50	>50	>50								
	VERT. SP	.010	.039	.088	.157	.245	.353	.480	.627	.794	.980								
	THROW	2-5	9-15	16-23	22-27	25-30	27-32	29-35	31-37	33-39	35-42								
	NC	<20	<20	<20	20	27	33	38	42	46	49								
2	HOR. SP		.022	.050	.089	.139	.200	.273	.356	.451	.557	.870							
	THROW		9-13	14-19	18-21	20-24	22-26	23-28	25-30	27-32	28-33	31-37							
	NC		<20	<20	<20	28	33	38	42	46	>50	>50							
	VERT. SP		.010	.022	.039	.061	.088	.120	.157	.199	.245	.383							
	THROW		3-6	7-13	12-21	19-26	23-31	27-35	30-37	33-39	35-42	39-46							
	NC		<20	<20	<20	<20	<20	<20	23	27	30	37							
3	HOR. SP			.022	.040	.062	.089	.121	.158	.200	.248	.387	.557						
	THROW			11-16	15-21	19-24	23-26	23-28	25-30	27-32	28-33	31-37	34-41						
	NC			<20	<20	<20	22	27	31	35	38	46	50						
	VERT. SP			.010	.017	.027	.039	.053	.070	.088	.109	.170	.245						
	THROW			4-8	7-13	10-20	15-26	20-30	25-34	28-38	31-42	39-46	43-51						
	NC			<20	<20	<20	<20	<20	<20	<20	<20	26	32						
4	HOR. SP				.022	.035	.050	.068	.089	.113	.139	.218	.313	.557					
	THROW				13-18	16-23	20-27	23-28	26-30	27-32	28-33	31-37	34-41	40-47					
	NC				<20	<20	<20	<20	24	27	31	38	43	>50					
	VERT. SP				.010	.015	.022	.030	.039	.050	.061	.096	.138	.245					
	THROW				4-9	7-13	10-18	13-25	17-30	22-33	27-36	34-46	40-51	50-58					
	NC				<20	<20	<20	<20	<20	<20	<20	<20	24	33					
5	HOR. SP					.022	.032	.044	.057	.072	.089	.139	.200	.356	.557				
	THROW					15-20	18-24	20-28	23-30	26-32	29-33	31-37	34-41	40-46	44-52				
	NC					<20	<20	<20	<20	21	24	32	37	46	>50				
	VERT. SP					.010	.014	.019	.025	.032	.039	.061	.088	.157	.245				
	THROW					5-10	7-13	9-18	12-23	16-29	19-33	30-41	36-49	48-58	56-65				
	NC					<20	<20	<20	<20	<20	<20	<20	<20	27	34				
6	HOR. SP						.022	.030	.040	.050	.062	.097	.139	.248	.387	.557			
	THROW						16-22	19-26	21-29	24-33	27-35	31-37	34-41	40-47	44-52	48-57			
	NC						<20	<20	<20	<20	<20	27	32	41	49	>50			
	VERT. SP						.010	.013	.017	.022	.027	.043	.061	.109	.170	.245			
	THROW						5-10	7-14	9-18	12-22	15-27	23-38	33-45	44-58	55-65	61-71			
	NC						<20	<20	<20	<20	<20	<20	<20	22	29	35			
7	HOR. SP							.022	.029	.037	.045	.071	.102	.182	.284	.409	.557		
	THROW							17-24	20-27	22-31	25-34	31-37	34-41	40-47	44-52	48-56	52-61		
	NC							<20	<20	<20	<20	22	28	37	44	50	>50		
	VERT. SP							.010	.013	.016	.020	.031	.045	.080	.125	.180	.245		
	THROW							6-11	7-14	9-18	12-22	18-33	26-42	41-55	51-65	61-70	66-77		
	NC							<20	<20	<20	<20	<20	<20	<20	25	31	37		
8	HOR. SP								.022	.028	.035	.054	.078	.139	.218	.313	.426	.557	
	THROW								18-26	21-29	23-32	29-37	35-41	40-47	44-52	48-56	52-61	56-66	
	NC								<20	<20	<20	<20	24	34	41	46	50	>50	
	VERT. SP								.010	.012	.015	.024	.034	.061	.096	.138	.188	.245	
	THROW								6-12	8-15	10-18	15-28	22-39	38-52	48-64	57-70	66-77	70-82	
	NC								<20	<20	<20	<20	<20	<20	21	27	32	36	

- NC Data based on 10dB room attenuation.
- Throw Data based on isothermal air at 100 and 50 fpm terminal velocity.
- Horizontal Throw is 1 way pattern.
- Static Pressure (SP) in inches w.g.



SUPPLY LINEAR SLOT AIR DIFFUSERS PERFORMANCE DATA

Model : LS3 - AD
Linear Diffuser 1" Slot Width

No. of Slots	CFM/FT.	10	20	30	40	50	60	70	80	90	100	125	150	200	250	300	350	400	
1	HOR. SP	.010	.040	.090	.160	.250	.360	.490	.640	.810	1.000								
	THROW	4-8	10-15	15-19	18-21	20-24	22-26	23-28	25-30	27-32	28-33								
	NC	<20	<20	25	34	41	47	>50	>50	>50	>50								
	VERT. SP	.007	.029	.066	.117	.183	.263	.358	.468	.592	.731								
	THROW	2-4	8-15	16-22	21-27	25-29	27-32	29-35	31-37	33-39	35-42								
	NC	<20	<20	<20	<20	21	27	32	36	40	43								
2	HOR. SP		.010	.023	.040	.063	.090	.122	.160	.203	.250	.391							
	THROW		6-11	11-15	14-20	18-24	22-26	23-28	25-30	27-32	28-33	31-37							
	NC		<20	<20	<20	22	28	33	37	41	44	50							
	VERT. SP		.007	.016	.029	.046	.066	.089	.117	.148	.183	.285							
	THROW		3-6	6-12	11-21	17-25	22-30	26-35	29-37	33-39	35-42	39-46							
	NC		<20	<20	<20	<20	<20	<20	<20	<20	21	24	31						
3	HOR. SP			.010	.018	.028	.040	.054	.071	.090	.111	.174	.250						
	THROW			7-13	12-17	15-21	18-24	21-28	23-30	26-32	28-33	31-37	34-41						
	NC			<20	<20	<20	<20	22	26	30	33	40	46						
	VERT. SP			.007	.013	.020	.029	.040	.052	.066	.081	.127	.183						
	THROW			3-7	6-12	9-18	13-24	18-29	24-33	27-37	30-41	37-46	43-51						
	NC			<20	<20	<20	<20	<20	<20	<20	<20	<20	<20	26					
4	HOR. SP				.010	.016	.023	.031	.040	.051	.063	.098	.141	.250					
	THROW				8-15	13-18	15-21	18-25	20-28	23-32	25-33	32-37	34-41	40-47					
	NC				<20	<20	<20	<20	<20	22	25	32	38	47					
	VERT. SP				.007	.011	.016	.022	.029	.037	.046	.071	.103	.183					
	THROW				4-8	6-12	9-17	12-22	16-29	20-32	24-36	32-44	39-51	50-58					
	NC				<20	<20	<20	<20	<20	<20	<20	<20	<20	<20	27				
5	HOR. SP					.010	.014	.020	.026	.032	.040	.063	.090	.160	.250				
	THROW					9-16	13-19	16-22	18-25	20-28	23-31	28-37	34-41	40-47	44-51				
	NC					<20	<20	<20	<20	<20	<20	26	32	41	48				
	VERT. SP					.007	.011	.014	.019	.024	.029	.046	.066	.117	.183				
	THROW					4-9	6-12	9-16	11-21	14-26	17-32	27-40	35-47	46-58	56-65				
	NC					<20	<20	<20	<20	<20	<20	<20	<20	<20	21	28			
6	HOR. SP						.010	.014	.018	.023	.028	.043	.063	.111	.174	.250			
	THROW						10-18	14-20	17-23	19-26	21-29	29-36	31-41	40-47	44-52	48-57			
	NC						<20	<20	<20	<20	<20	21	27	36	43	49			
	VERT. SP						.007	.010	.013	.016	.020	.032	.046	.081	.127	.183			
	THROW						5-9	6-13	8-16	11-20	13-25	21-36	20-43	42-58	53-65	61-71			
	NC						<20	<20	<20	<20	<20	<20	<20	<20	<20	23	29		
7	HOR. SP							.010	.013	.017	.020	.032	.046	.082	.128	.184	.250		
	THROW							11-19	14-22	17-24	19-27	24-33	29-39	38-47	44-52	48-57	52-61		
	NC							<20	<20	<20	<20	<20	23	32	39	45	50		
	VERT. SP							.007	.010	.012	.015	.023	.034	.060	.093	.134	.183		
	THROW							5-10	7-13	9-16	11-20	16-30	24-40	39-53	49-65	59-71	66-77		
	NC							<20	<20	<20	<20	<20	<20	<20	<20	<20	25	30	
8	HOR. SP								.010	.013	.016	.024	.035	.063	.098	.141	.191	.250	
	THROW								12-20	15-23	18-25	22-31	27-37	36-47	45-52	48-57	52-61	56-66	
	NC								<20	<20	<20	<20	<20	28	35	41	46	50	
	VERT. SP								.007	.009	.011	.018	.026	.046	.071	.103	.140	.183	
	THROW								6-11	7-13	9-16	13-25	19-35	34-50	46-62	55-71	64-77	70-82	
	NC								<20	<20	<20	<20	<20	<20	<20	<20	21	26	30

- NC Data based on 10dB room attenuation.
- Throw Data based on isothermal air at 100 and 50 fpm terminal velocity.
- Horizontal Throw is 1 way pattern.
- Static Pressure (SP) in inches w.g.

RETURN LINEAR SLOT AIR DIFFUSERS PERFORMANCE DATA

Model : LS3 - A

Linear slot diffuser with deflection blades and without volume control damper (3/4" Slot Width).

No. of Slots	Negative SP	.005	.022	.048	.086	.133	.196	.270	.354
1	CFM/Foot	10	20	30	40	50	60	70	80
	NC	<20	<20	<20	<20	25	31	36	40
2	CFM/Foot	20	40	60	80	100	120	140	160
	NC	<20	<20	<20	23	27	33	38	42
3	CFM/Foot	30	60	90	120	150	180	210	240
	NC	<20	<20	23	29	33	39	44	46
4	CFM/Foot	40	80	120	160	200	240	280	320
	NC	<20	<20	26	32	36	42	47	50
5	CFM/Foot	50	100	150	200	250	300	350	400
	NC	<20	<20	28	34	38	44	49	>50
6	CFM/Foot	60	120	180	240	300	360	420	480
	NC	<20	23	31	36	40	46	>50	>50
7	CFM/Foot	70	140	210	280	350	420	490	560
	NC	<20	23	31	37	42	48	>50	>50
8	CFM/Foot	80	160	240	320	400	480	560	640
	NC	<20	24	32	38	44	>50	>50	>50

Model : LS3 - D

Linear slot diffuser without deflection blades and with volume control damper (3/4" Slot Width).

No. of Slots	Negative SP	.015	.062	.134	.241	.372	.549	.756	.991
1	CFM/Foot	10	20	30	40	50	60	70	80
	NC	<20	<20	<20	22	27	32	37	42
2	CFM/Foot	20	40	60	80	100	120	140	160
	NC	<20	<20	24	32	38	43	48	>50
3	CFM/Foot	30	60	90	120	150	180	210	240
	NC	<20	<20	30	38	42	49	>50	>50
4	CFM/Foot	40	80	120	160	200	240	280	320
	NC	<20	23	34	43	48	>50	>50	>50
5	CFM/Foot	50	100	150	200	250	300	350	400
	NC	<20	26	38	46	>50	>50	>50	>50
6	CFM/Foot	60	120	180	240	300	360	420	480
	NC	<20	29	40	48	>50	>50	>50	>50
7	CFM/Foot	70	140	210	280	350	420	490	560
	NC	<20	31	43	>50	>50	>50	>50	>50
8	CFM/Foot	80	160	240	320	400	480	560	640
	NC	<20	33	45	>50	>50	>50	>50	>50

- NC Data based on 10dB room attenuation.
- Static Pressure (SP) in inches w.g.

RETURN LINEAR SLOT AIR DIFFUSERS PERFORMANCE DATA

Model : LS3 - A

Linear slot diffuser with deflection blades and without volume control damper (1" Slot Width).

No. of Slots	Negative SP	.016	.034	.055	.086	.123	.161	.205	.354
1	CFM/Foot	20	30	40	50	60	70	80	100
	NC	<20	<20	<20	<20	24	27	30	35
2	CFM/Foot	40	60	80	100	120	140	160	200
	NC	<20	<20	<20	22	26	29	33	37
3	CFM/Foot	60	90	120	150	180	210	240	300
	NC	<20	<20	<20	24	28	31	34	39
4	CFM/Foot	80	120	160	200	240	280	320	400
	NC	<20	<20	<20	25	29	32	35	40
5	CFM/Foot	100	150	200	250	300	350	400	500
	NC	<20	<20	21	26	30	33	36	41
6	CFM/Foot	120	180	240	300	360	420	480	600
	NC	<20	<20	22	27	31	34	37	42
7	CFM/Foot	140	210	280	350	420	490	560	700
	NC	<20	<20	23	28	32	35	38	43
8	CFM/Foot	160	240	320	400	480	560	640	800
	NC	<20	<20	24	29	33	36	39	45

Model : LS3 - D

Linear slot diffuser without deflection blades and with volume control damper (1" Slot Width).

No. of Slots	Negative SP	.026	.095	.154	.240	.344	.451	.574	.991
1	CFM/Foot	20	30	40	50	60	70	80	100
	NC	<20	<20	<20	21	26	30	32	38
2	CFM/Foot	40	60	80	100	120	140	160	200
	NC	<20	<20	23	29	31	37	41	44
3	CFM/Foot	60	90	120	150	180	210	240	300
	NC	<20	<20	25	32	36	40	45	50
4	CFM/Foot	80	120	160	200	240	280	320	400
	NC	<20	22	26	34	39	43	48	>50
5	CFM/Foot	100	150	200	250	300	350	400	500
	NC	<20	24	29	36	42	45	50	>50
6	CFM/Foot	120	180	240	300	360	420	480	600
	NC	<20	26	32	39	45	49	>50	>50
7	CFM/Foot	140	210	280	350	420	490	560	700
	NC	<20	29	36	43	48	>50	>50	>50
8	CFM/Foot	160	240	320	400	480	560	640	800
	NC	<20	31	40	46	>50	>50	>50	>50

- NC Data based on 10dB room attenuation.
- Static Pressure (SP) in inches w.g.

BALANCING DATA

Supply Air Testing

Step 1 : Place an Anor jet # 2220A as per sketch, and take velocity readings at frequent intervals along one slot of a group of slots having the same blade settings.

Take readings at approximately 6" from end and at 1 foot intervals, being careful to avoid readings directly below spacer bars which are at 18" intervals. Take atleast four readings on units under 4 feet long.

Average the readings to obtain Average Velocity (V_k).

Step 2 : From table select the A_k for number of slots which have the same blade settings.

Step 3 : Determine L as the length in feet of the section of slots having the same settings.

Step 4 : Calculate CFM.

a. For Horizontal

Measure V_k on the side of slot as shown in Fig (1).

Take A_k from table.

$$\text{Total CFM} = A_k \times V_k \times L.$$

b. For Vertical

Measure V_k on one side of the slot as shown in Fig (2).

Take A_k from table.

$$\text{Total CFM} = A_k \times V_k \times L.$$

Return Air Testing

Measure V_k in the open side of the slot as shown in Fig (3).

Take A_k from table.

$$\text{Total CFM} = A_k \times V_k \times L.$$

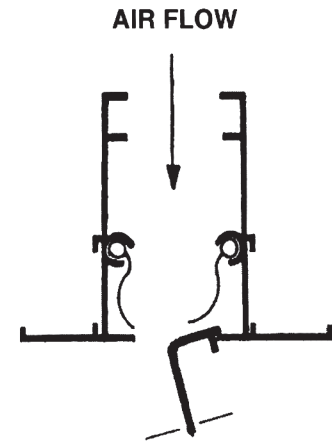

Fig. (1)

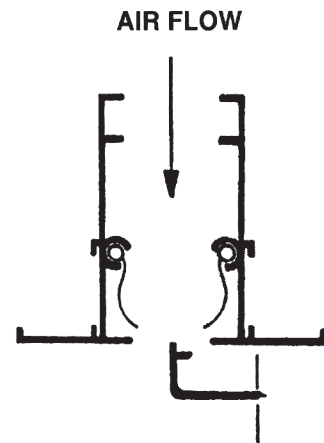

Fig. (2)

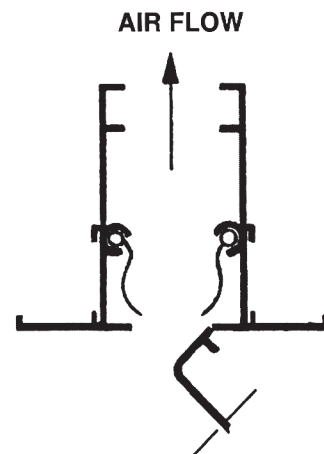
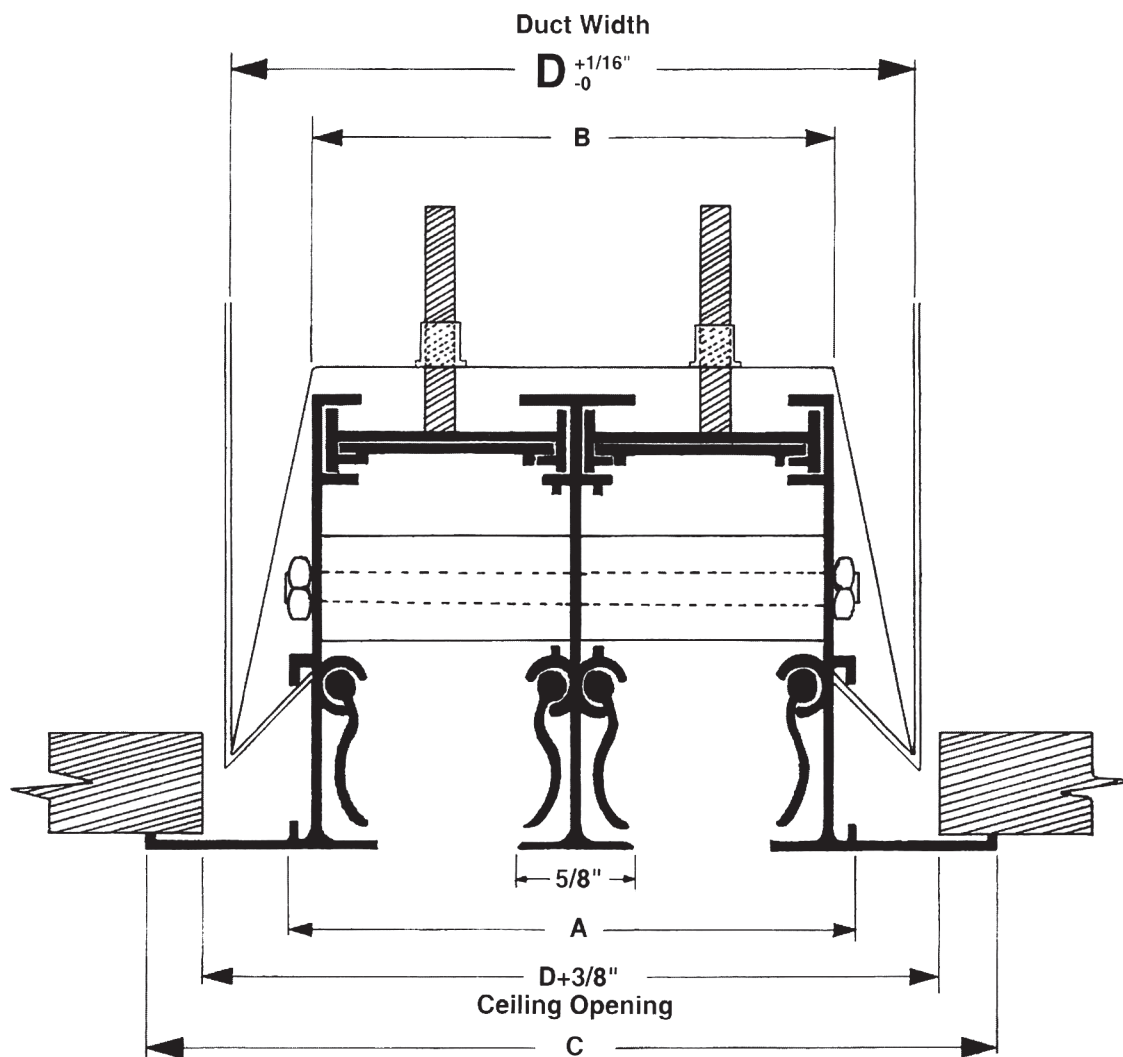

Fig. (3)

INSTALLATION DETAILS



Ceiling Opening for 3/4" Slot Width

No. of Slots	1	2	3	4	5	6	7	8
A (in.)	1.65	2.99	4.33	5.67	7.01	8.35	9.65	10.94
B (in.)	1.42	2.76	4.09	5.43	6.81	8.15	9.41	10.71
C (in.)	3.31	4.61	5.94	7.28	8.58	9.96	11.38	12.64
D (in.)	2.28	3.62	4.95	6.29	7.67	9.01	10.27	11.57

Ceiling Opening for 1" Slot Width

No. of Slots	1	2	3	4	5	6	7	8
A (in.)	1.94	3.58	5.23	6.88	8.52	10.17	11.81	13.46
B (in.)	1.70	3.35	4.99	6.64	8.28	9.93	11.58	13.22
C (in.)	3.48	5.13	6.77	8.42	10.06	11.71	13.36	15.00
D (in.)	2.57	4.21	5.86	7.50	9.15	10.80	12.44	14.09

CURVE LINEAR SLOT DIFFUSERS ENGINEERING CALCULATION



R - Radius up to grille inside. R

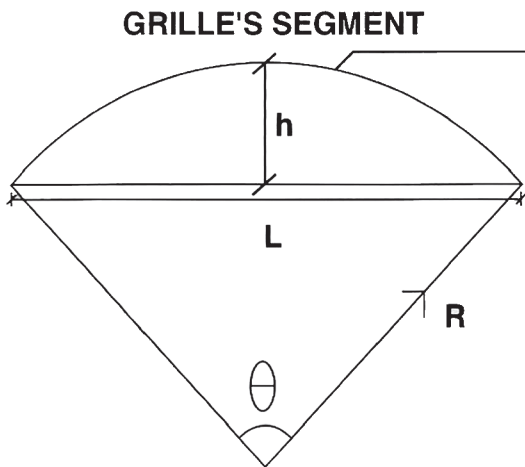

Grille Arch Length. (A/L).

$$A/L = \theta \times (\pi/180) \times R$$

θ - Angle, R - Radius

$$h = \text{Segment Height.} \\ = R \times (1 - \cos(\theta/2)).$$

$$L = \text{Segment Length.} \\ = 2 \times R \times (\sin(\theta/2)).$$

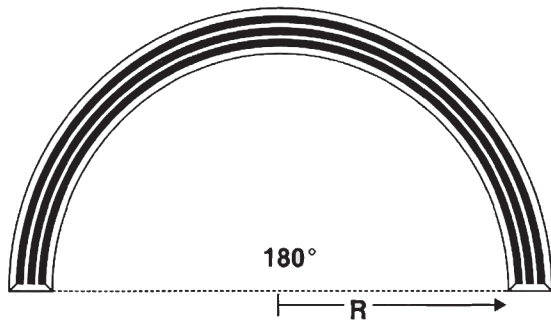

Semi-Circular Grille ; Arch Length = $\pi \times R$.

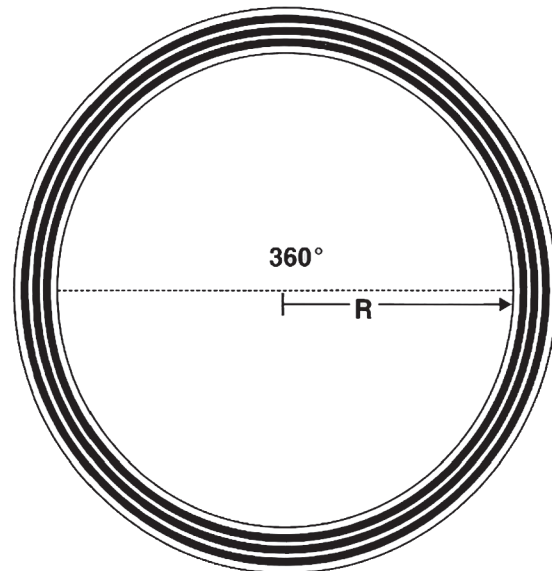

Full-Circular Grille ; Arch Length = $2 \times \pi \times R$.

NOTES:

- All Curved Linear Slot Diffusers are ceiling mount.
- The least radius of curvature is 1.5 meters.
- Hit & miss damper for above diffusers will not be provided.
- Full function of deflector (pattern controllers) may not be obtained in above diffusers.

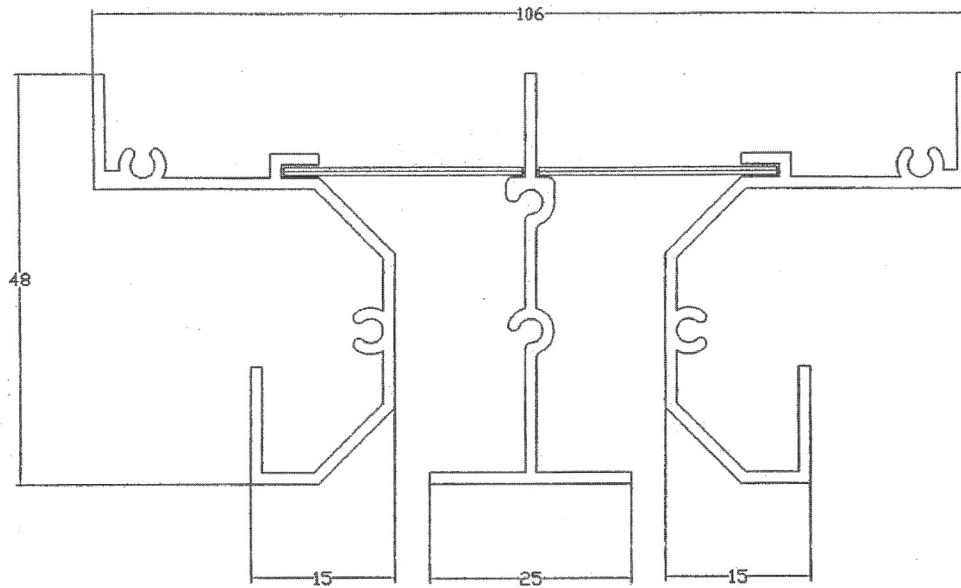

PRODUCT DESCRIPTION

- T slot diffuser with fixed deflection and control damper is constructed of extruded aluminium alloy and are polyester powder coated finish.
- The air flow pattern can be varied without changing the air pattern by the use of volume control damper attached to the rear side of the diffuser.
- Designed to give excellent performance and blend in harmoniously with ceiling architecture such that ceiling tiles can be rested on the diffuser face, while providing extraordinary air distribution qualities.
- Standard finish is white colour for outer frames and black colour for inner frame & damper. Painted under electrostatic powder system. Other colors available on request. The polyester powder of highest quality are used to enhance the appearance of the units.
- T slot diffuser handles large volume of air at low pressure drop and noise level.
- Maximum length supplied 10 feet.
- The slots are available in 3/4"
- The volume control damper consists of two strips of aluminium, one fixed and one movable, they both have rectangular holes & it can also be works as equalizing grid.

T-SLOT AIR DIFFUSER PERFORMANCE DATA

Model: TS3-D

T-SLOT DIFFUSER

NO. OF SLOTS	CFMT/FT	10	20	30	40	50	60	70	80	90	100	125	125	200
1	SP, IN. WG.	0.01	0.03	0.06	0.10	0.14								
	THROW, FT.	10-12	15-19	16-21	18-25	20-28								
	N.C.	<20	<20	20	23	26								
2	SP, IN. WG.		0.01	0.02	0.03	0.06	0.07	0.08	0.09	0.12	0.15			
	THROW, FT.	7-9	8-11	10-15	13-18	16-20	17-22	20-23	20-26	24-28	26-30			
	N.C.		<20	<20	20	22	25	27	30	31	33			
3	SP, IN. WG.			0.015	0.020	0.025	0.030	0.040	0.050	0.060	0.080	0.100	0.150	
	THROW, FT.			9-11	10-14	12-16	13-19	18-21	20-23	22-26	24-27	24-28	26-31	
	N.C.			<20	<20	20	21	23	25	27	28	30	32	
4	SP, IN. WG.				0.015	0.020	0.022	0.024	0.030	0.040	0.050	0.060	0.10	0.150
	THROW, FT.				9-12	10-14	12-16	14-20	18-22	20-24	22-25	22-26	25-30	28-36
	N.C.				<20	<20	<20	22	23	24	28	28	30	35

- NC Data based on 10dB room attenuation
- Throw Databased on isothermal air at 100 and 50 fpm terminal velocity