

جي جي سي

G G C

شركة الخليج لفتحات التكييف المركزي
GULF GRILLES CO.



LOUVERS

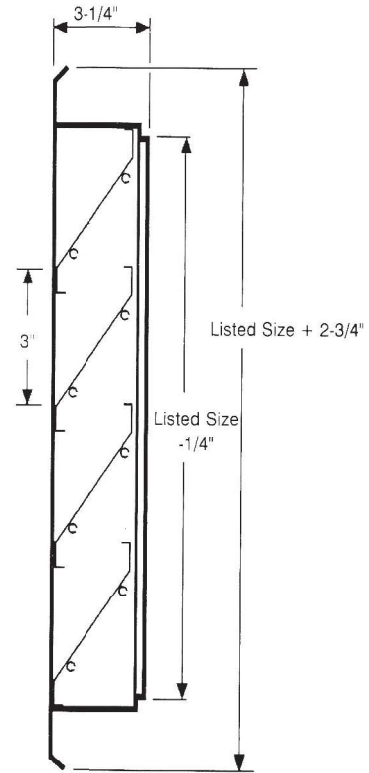

PRODUCT DESCRIPTION

- The frame and blades are extruded aluminium alloy and are polyester powder coated with a white finish.
- The frame and blades have a typical wall thickness of 1/16".
- The blades are spaced 3" on center and are set at 45° to the horizontal.
- An expanded aluminium bird screen is attached to the interior face of the louver.
- Standard finish is white color for frame and blades. Painted under electrostatic polyester powder coated system. Other colors available on request. The polyester powder of highest quality are used to enhance the appearance of the units.

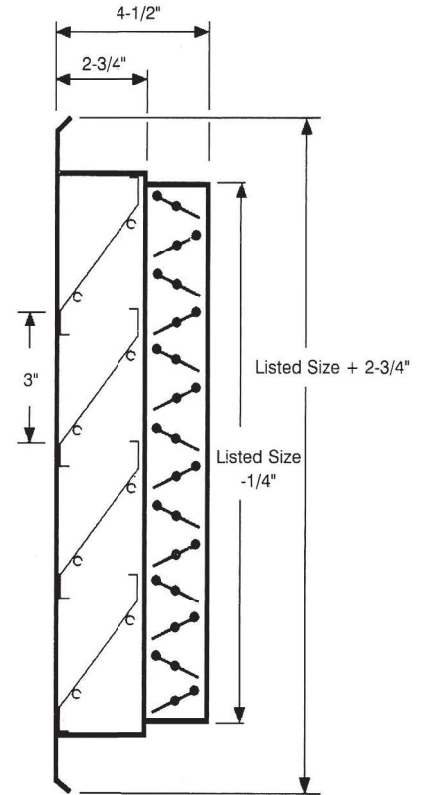

PRODUCT DESCRIPTION

- The frame and blades are extruded aluminium alloy and are polyester powder coated with a white finish.
- The frame and blades have a typical wall thickness of 1/16".
- The blades are spaced 3" on center and are set at 45° to the horizontal.
- An expanded aluminium bird screen is attached to the interior face of the louver.
- Standard finish is white color for frame and blades, damper in black color. Painted under electrostatic polyester powder coated system. Other colors available on request. The polyester powder of highest quality are used to enhance the appearance of the units.

FRESH AIR LOUVERS PERFORMANCE DATA



GRAPHICAL TEST RESULTS

WITH FILTER

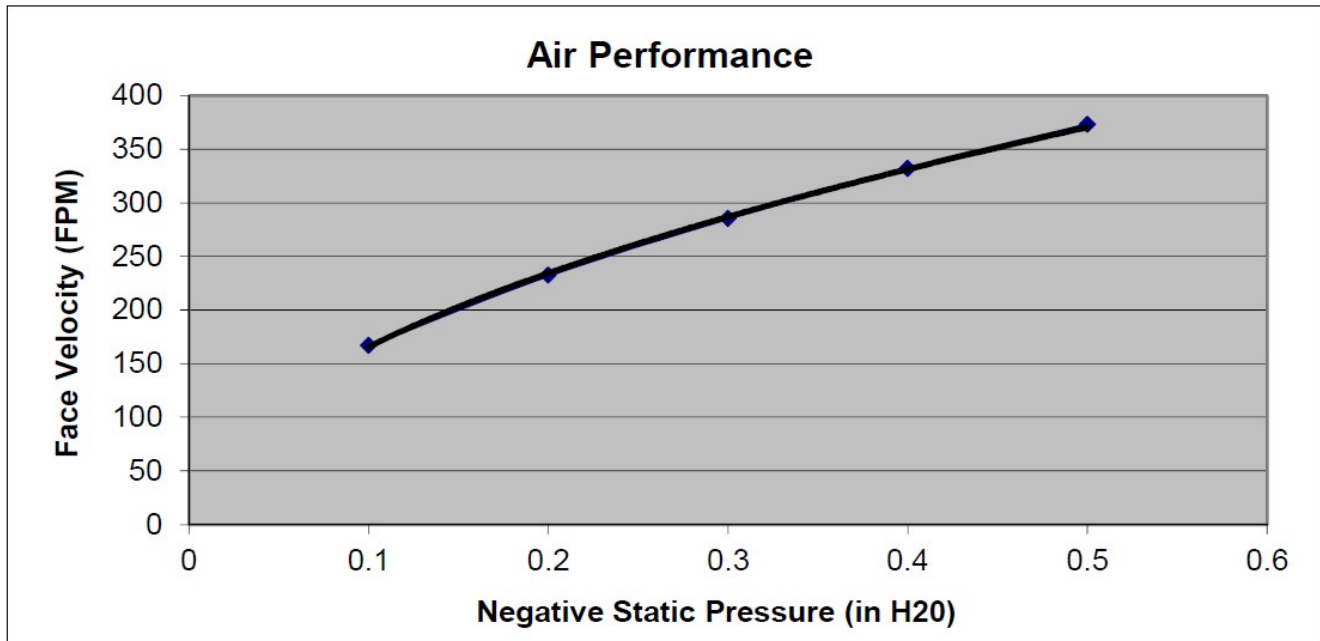

WITHOUT FILTER

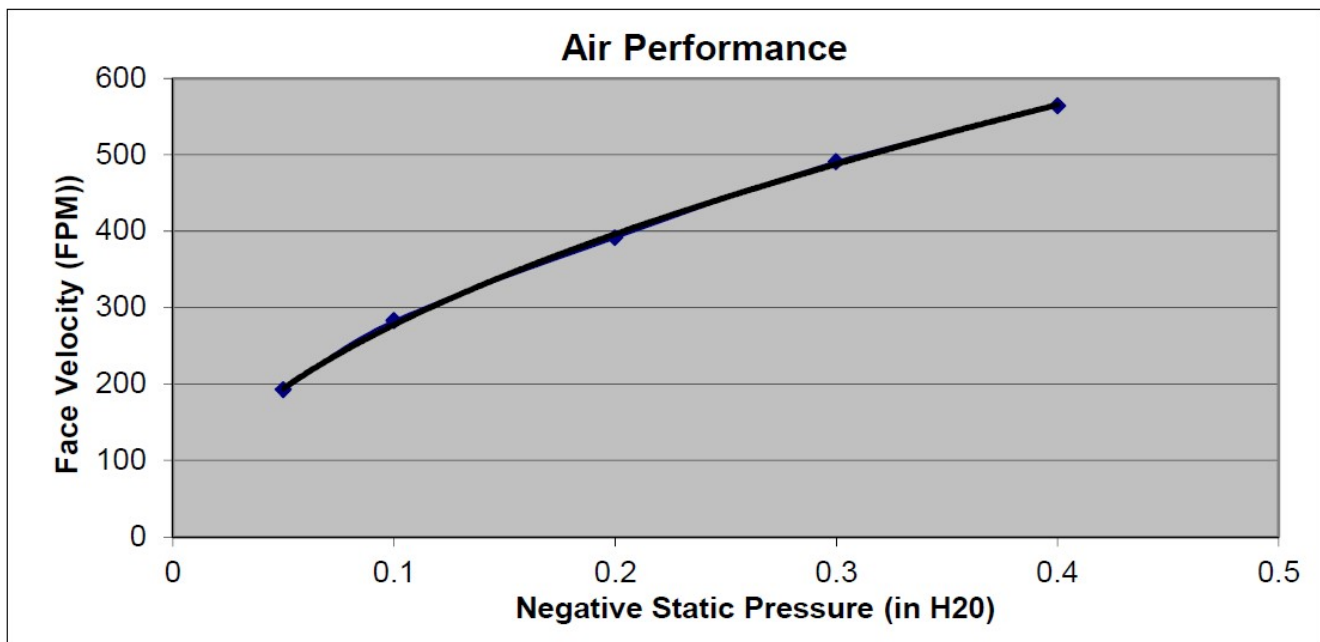

INSTALLATION DETAILS

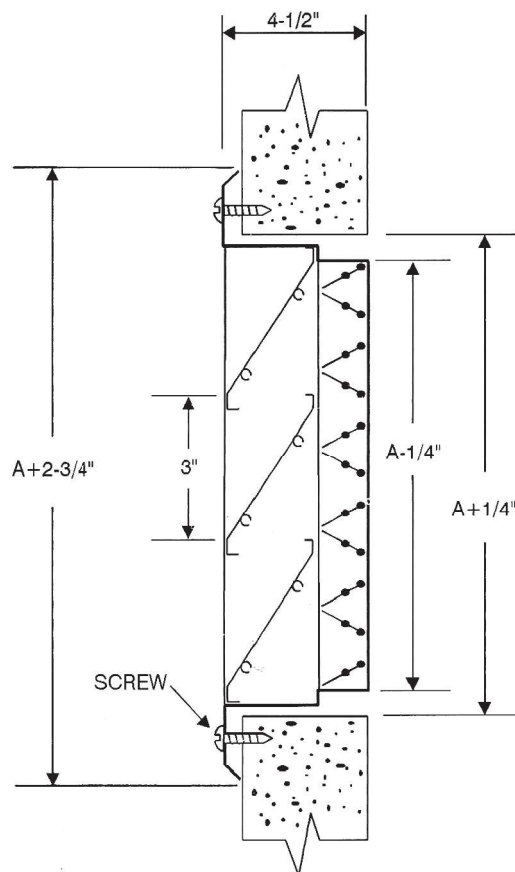
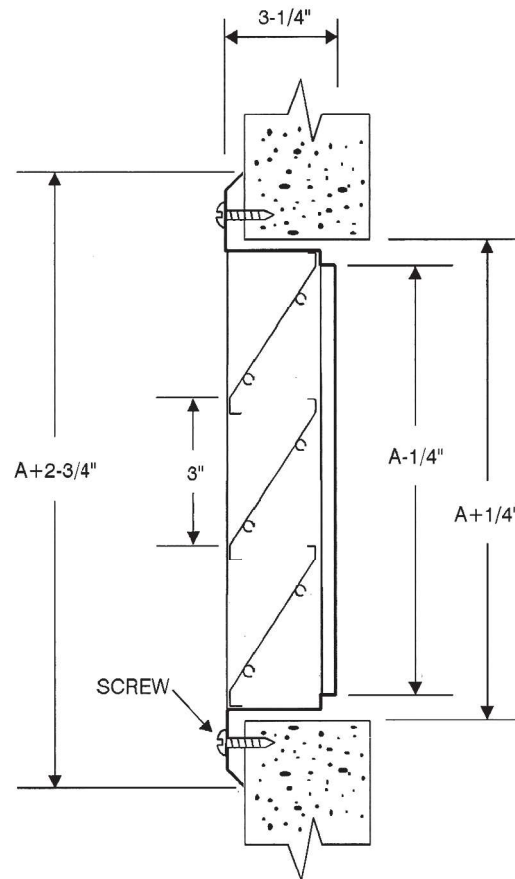

A = LISTED SIZES (W x H)

FRESH AIR LOUVER ASSEMBLY ALUMINUM FILTER & VOLUME CONTROL DAMPER

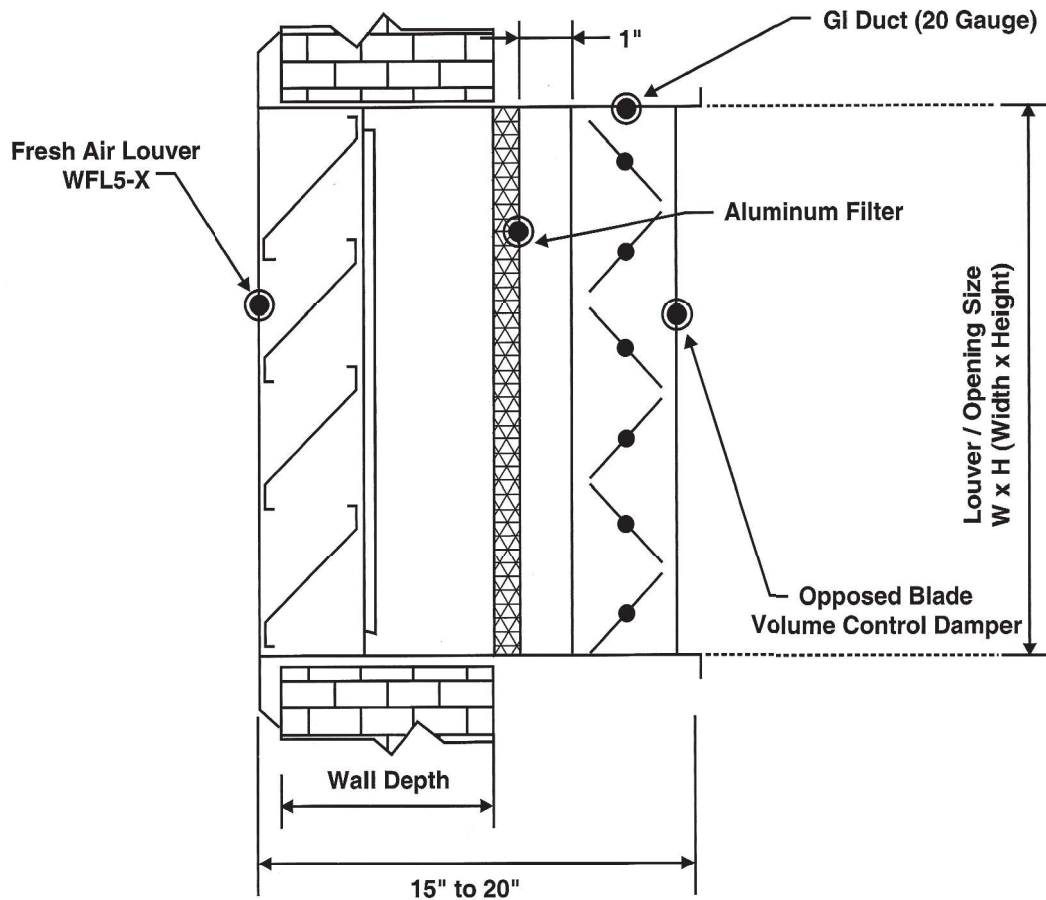

OPTIONS AVAILABLE:

- Opposed Blade Volume Control Damper - Manual Operation through Quadrant Regulator with handle.
- Opposed Blade Volume Control Damper - Motorized Operation through Actuator (3-position - OR - On/Off spring return 2-position).
- Washable Aluminum Filter (1" - OR - 2"THICK) - spring mount and removable from louver/duct rear - OR - Rail mount removable through access door with dome lock and nut.
- GI duct bend or MS Steel angle as flange at the end of assembly - OR - S - & - DRIVE (Slipjoint - C-Clip) - OR - Plain Duct Casing.

Notes:

The order from customer should confirm the position of damper quadrant/actuator and access door for aluminum filter to position at either right or left side from louver front.

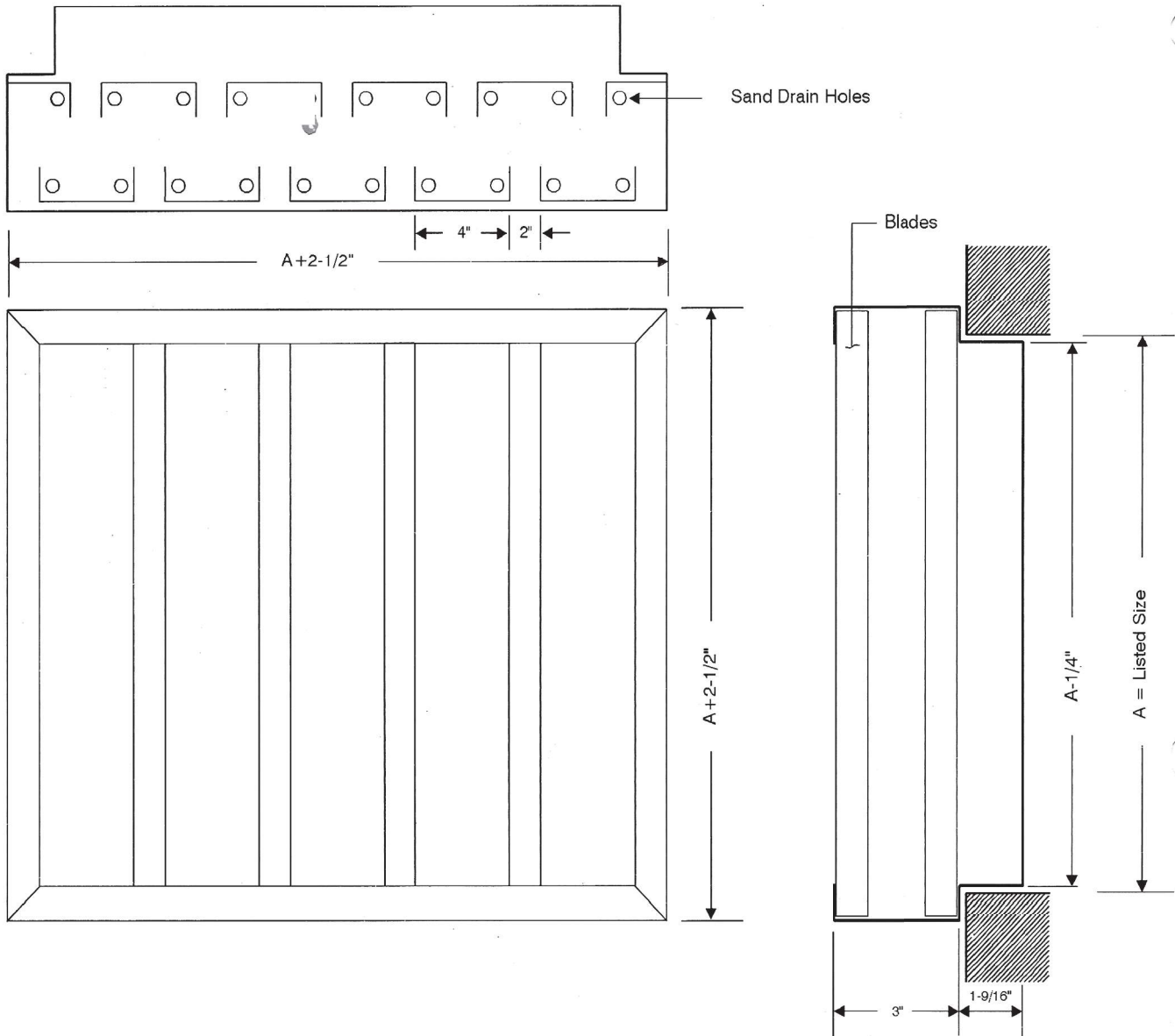

PRODUCT DESCRIPTION

- The louver is used for sandy areas to separate sand from intake air.
- The frame and blades are extruded aluminium alloy and are polyester powder coated with a white finish.
- The frame has a typical wall thickness of 5/64" and blades have a thickness of 1/16".
- Provided with self emptying sand drain holes from the base.
- Standard finish is white color for frame and blades. Painted under electrostatic polyester powder coated system. Other colors available on request. The polyester powder of highest quality are used to enhance the appearance of the units.
- As an option an expanded galvanized bird screen and aluminium filter can be attached to the interior face of the louver.

EFFECTIVE PRESSURE AREAS FT²

Height (inches)	Width (inches)													
	12	18	24	30	36	42	48	54	60	66	72	78	84	90
12	0.31	0.47	0.64	0.79	0.96	1.12	1.28	1.44	1.60	1.77	1.93	2.09	2.25	2.41
18	0.47	0.72	0.96	1.21	1.45	1.70	1.94	2.19	2.43	2.68	2.92	3.17	3.41	3.66
24	0.64	0.96	1.29	1.62	1.95	2.78	2.60	2.93	3.26	3.59	3.92	4.24	4.57	4.90
30	0.79	1.21	1.62	2.03	2.44	2.85	3.27	3.68	4.09	4.50	4.91	5.32	5.73	6.15
36	0.96	1.45	1.95	2.44	2.94	3.43	3.93	4.42	4.92	5.41	5.91	6.40	6.89	7.39
42	1.04	1.57	2.11	2.65	3.19	3.72	4.26	4.79	5.33	5.87	6.40	6.94	7.47	8.01
48	1.20	1.82	2.44	3.06	3.68	4.30	4.92	5.54	6.16	6.78	7.40	8.02	8.64	9.26
54	1.36	2.06	2.77	3.47	4.17	4.87	5.58	6.28	6.98	7.69	8.39	9.10	9.80	10.50
60	1.52	2.31	3.09	3.88	4.67	5.45	6.24	7.03	7.81	8.60	9.39	10.17	10.96	11.75
66	1.69	2.55	3.42	4.29	5.16	6.03	6.90	7.77	8.64	9.51	10.38	11.25	12.12	13.00
72	1.85	2.80	3.75	4.71	5.66	6.61	7.57	8.52	9.47	10.42	11.38	12.33	13.28	14.23
78	2.01	3.04	4.08	5.12	6.15	7.19	8.23	9.26	10.30	11.33	12.37	13.41	14.44	15.48
84	2.17	3.29	4.41	5.53	6.65	7.77	8.89	10.01	11.13	12.25	13.37	14.49	15.61	16.72
90	2.33	3.53	4.74	5.69	7.14	8.35	9.55	10.75	11.96	13.16	14.36	15.56	16.77	17.97

PERFORMANCE

Test results conducted on similar equipment indicate a typical efficiency of 80% on AC coarse (20 - 200 microns) and 50% on AC Fine test duct (1 to 70 microns).

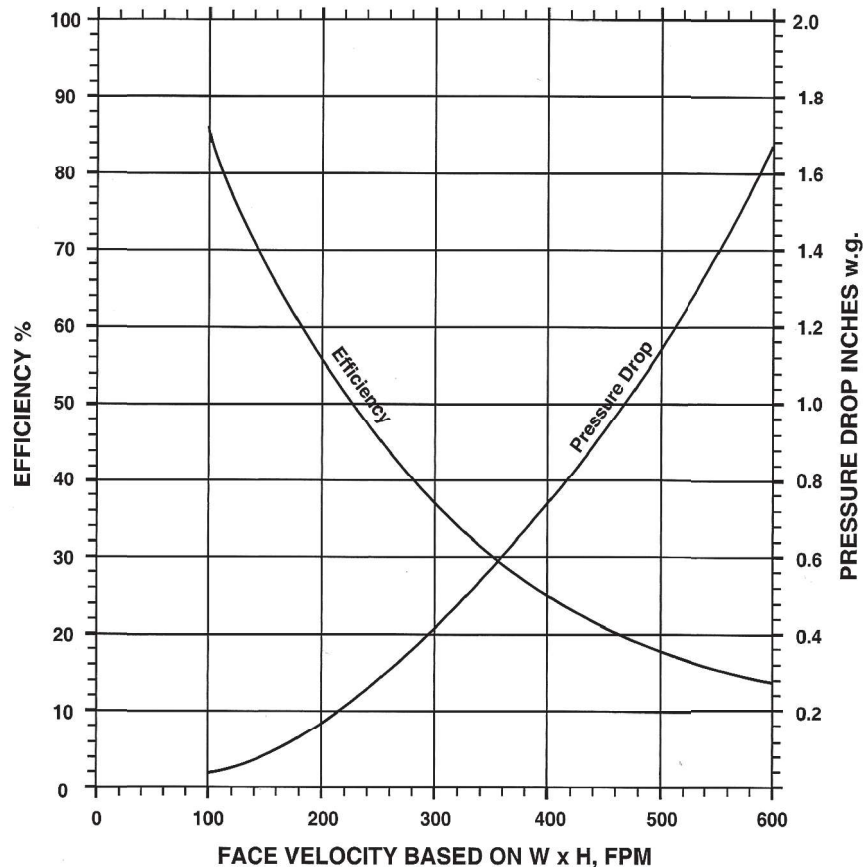

SAND TRAP LOUVER ASSEMBLY ALUMINUM FILTER & VOLUME CONTROL DAMPER

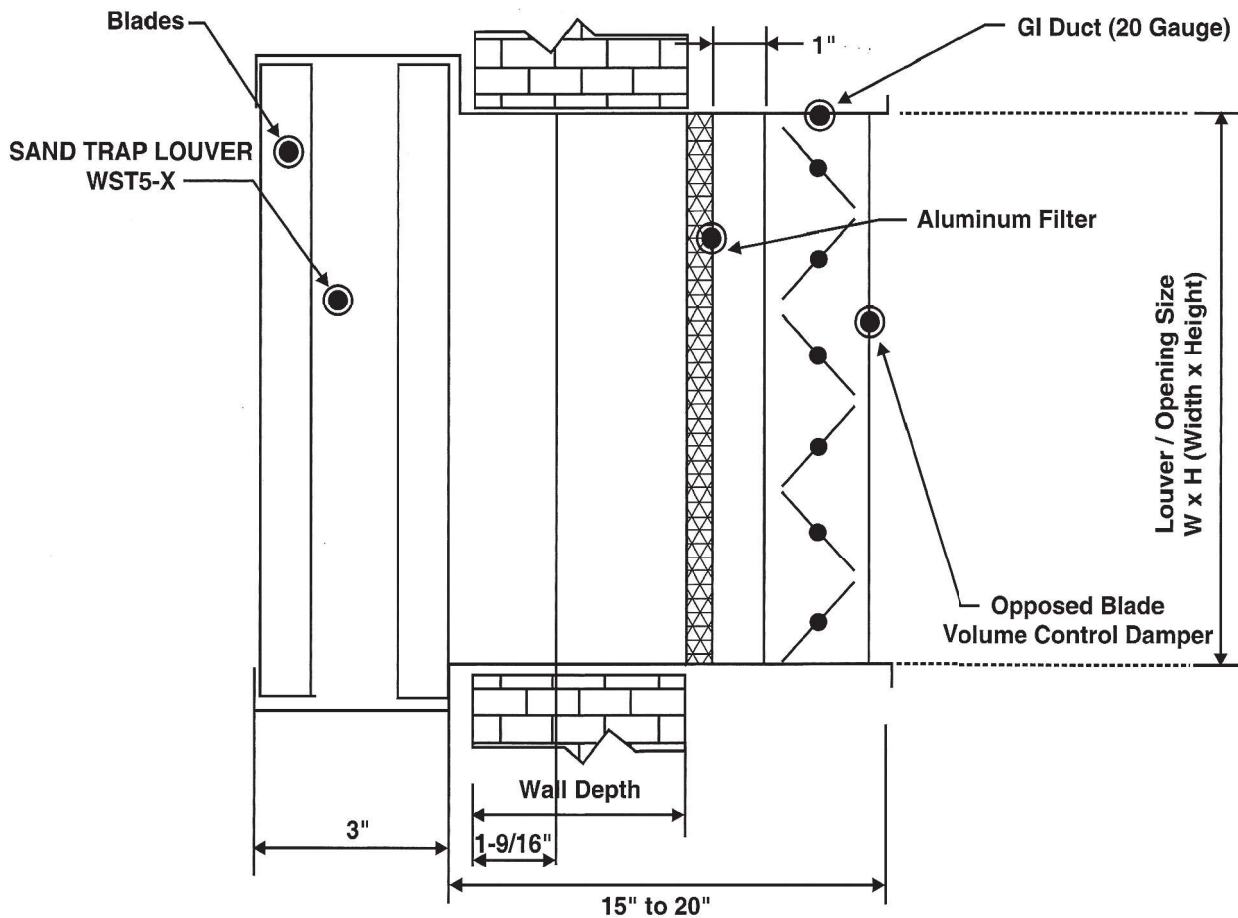

OPTIONS AVAILABLE:

- Opposed Blade Volume Control Damper - Manual Operation through Quadrant Regulator with handle.
- Opposed Blade Volume Control Damper - Motorized Operation through Actuator (3-position - OR - On/Off spring return 2-position).
- Washable Aluminum Filter (1" - OR - 2" THICK) - spring mount and removable from louver/duct rear - OR - Rail mount removable through access door with dome lock and nut.
- GI duct bend or MS Steel angle as flange at the end of assembly - OR - S - & - DRIVE (Slip joint - C-Clip) - OR - Plain Duct Casing.

Notes:

The order from customer should confirm the position of damper quadrant/actuator and access door for aluminum filter to position at either right or left side from louver front.

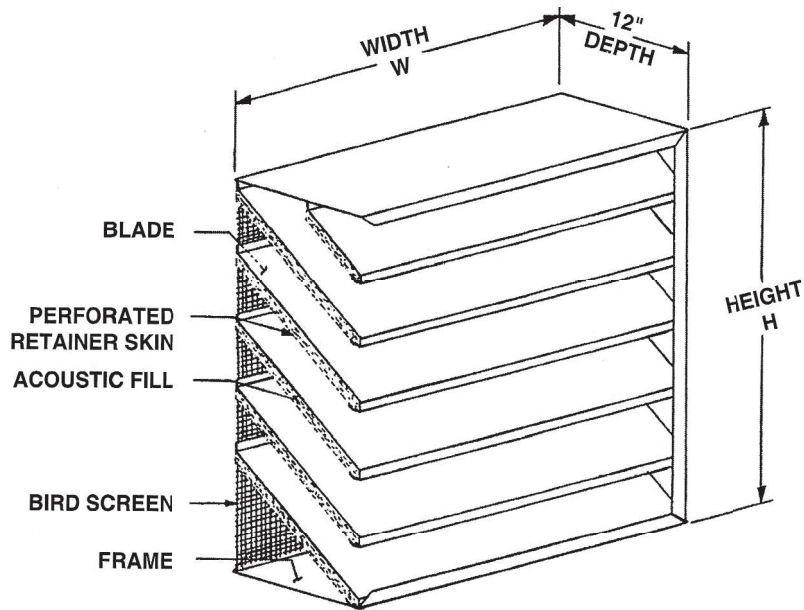

STANDARD CONSTRUCTION

Acoustic Louvers are designed for sound attenuation.

- The frame and blades are 16 gauge (1/16") aluminium alloy or frame 18 gauge (3/64") and blades 24 gauge (1/32") galvanized steel sheet.
- The edges of front and back of the frame are folded to give additional strength.
- The blade elements are set at 45° with a 5-3/4" pitch and have a raised tip to prevent the ingress of rain.
- The underside of all blades is filled with fiber glass insulation, and retained and faced with 24 gauge (1/32") perforated aluminum.
- The sound absorbing (insulation) packing is inert, non-combustible, non-hygroscopic and vermin proof.
- Louvers can be fitted with a bird screen as an option. They are constructed from expanded steel sheet galvanized after manufacture having a free area of 85%.
- The overall casing depth is 12". The maximum single size is 90" high and 70" wide overall. Where louvers are required larger than this, it is necessary to specify a multisection unit.
- Standard finish is white for frame and blades. Painted under electrostatic polyester powder coated system. Other colors available on request. The polyester powder of highest quality are used to enhance the appearance of the units.
- Applications : The louver provides an ideal acoustic/ weather barrier wherever ventilation apertures are created in structure. Applications are numerous and some of the more common are listed below.
 - 1. Air inlets and outlets :**
Air conditioning plants, processing plants, standby diesel generating sets, underground or enclosed car parks.
 - 2. Screened walls :**
Cooling towers, air cooled condensers.
 - 3. Ventilated enclosures :**
Air conditioning Plan, electrical generation plant

ACOUSTIC LOUVERS PERFORMANCE DATA

Pressure Drop

Face Velocity, in FPM	100	150	200	250	300	350	400	450	500	550	600
Pressure Drop, (in. W.G.)	.008	.012	.024	.036	.052	.068	.092	.112	.140	.168	.200

Transmission Loss

Octave Band Number	1	2	3	4	5	6	7	8
Centre frequency, HZ	63	125	250	500	1k	2k	4k	8k
Transmission Loss, in dB	5	5	7	12	18	21	16	16

PERFORMANCE NOTE :

The acoustic performance is as detailed above and is presented as a sound reduction index (transmission loss) which can be defined as being a function of practical usage, the performance figures quoted above may be used in the same way as the conventional static insertion loss of an attenuator.

ASSEMBLY OF MULTIPLE UNITS

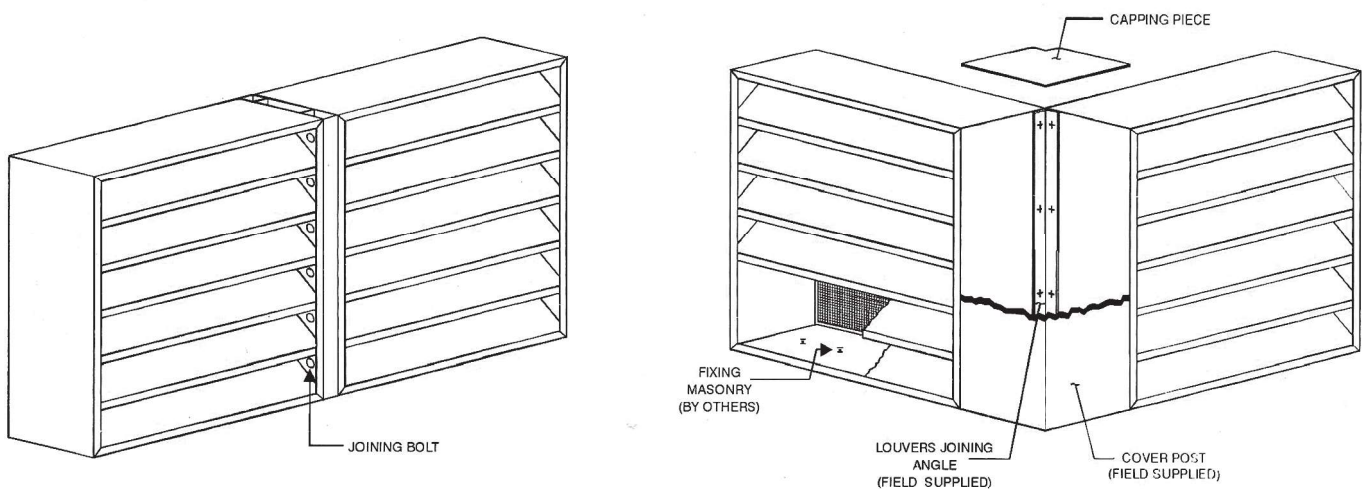

INSTALLATION DETAILS

Installation in Structural Opening

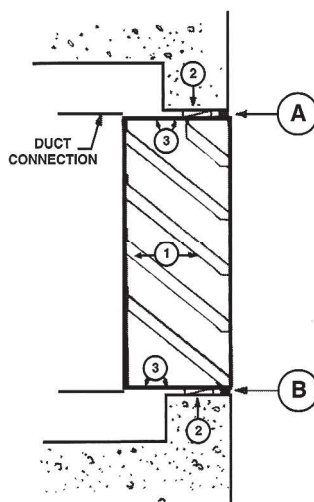

FIXING METHODS

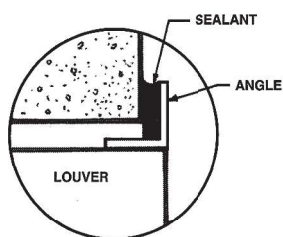

A
LOUVER MUCH DEEPER THAN WALL

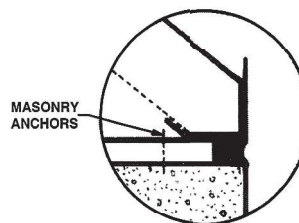

B
LOUVER IN WALL OF SIMILAR DEPTH

The recommended method of installation is shown in the above diagram by steps.

1. Set the louver assembly square and true in wall - from the interior or exterior (where angles are fitted to the outside perimeter of the louver, access is only possible from the exterior).
2. Wedge and pack between the louver and the structure from both sides.
3. Fixing to surrounding structure. The louver is wider in section than the wall, by use of angle frame fixing from the rear. (See Section A). The louver section similar in depth, where a wooden sub-frame is employed fixing is via the holes

drilled in the side of the units. Where no sub frame can be used, fixing is direct to the structure through the sides at positions compatible with the form of structure. (See Section B).

Seal around the perimeter of the louver from the exterior by injection of polysulphide sealant between casing and builders work. Where angle trim is used, the building side of the trim should be covered in sealant prior to insertion of the louver and the seal made good. (See Section A and B).

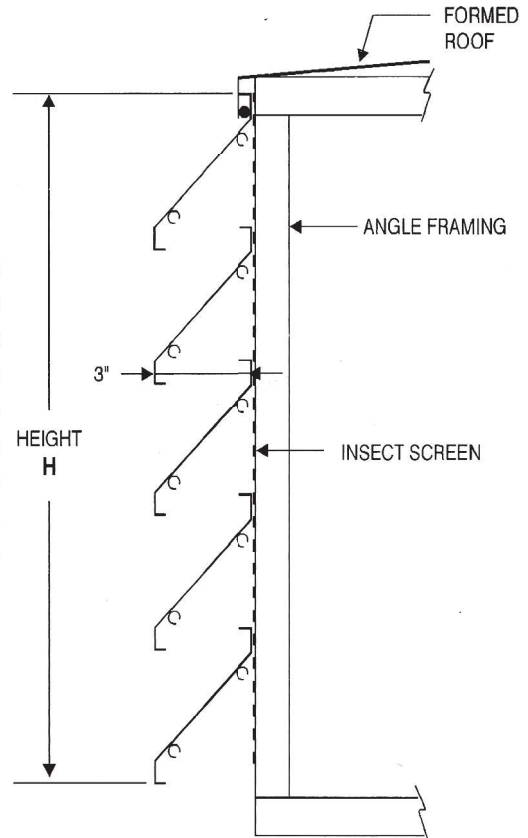
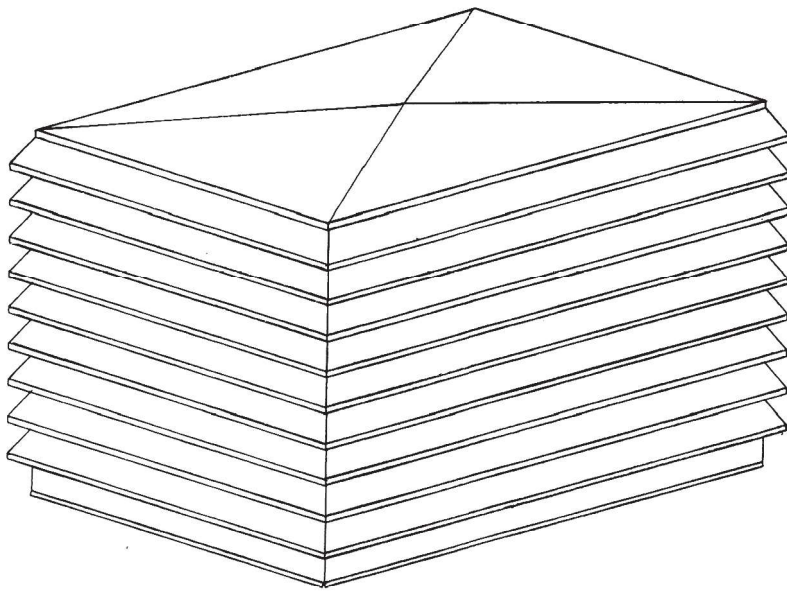

PRODUCT DESCRIPTION

Penthouse Louvers which is an ideal roof mounted units designed for air intake, pressure-relief and exhaust applications.

- The blades are 1/16" thick extruded aluminium alloy and are polyester powder coated with a white finish.
- The integral angles are furnished with 1-1/4" x 1-1/4" x 1/8" extruded aluminum.
- The top of the unit is covered with hinged access door for easy access.
- Bird screen to prevent the entry of birds to the louver as an option.
- 1" thick aluminum washable filters available on request, which could be removed for cleaning, replaced from the top of unit.
- Standard finish is white for blades and angles. Painted under electrostatic polyester powder coated system. Other colors available on request. The polyester powder of highest quality are used to enhance the appearance of the units.

PENTHOUSE LOUVERS

PENTHOUSE DYNAMICS AND SIZING

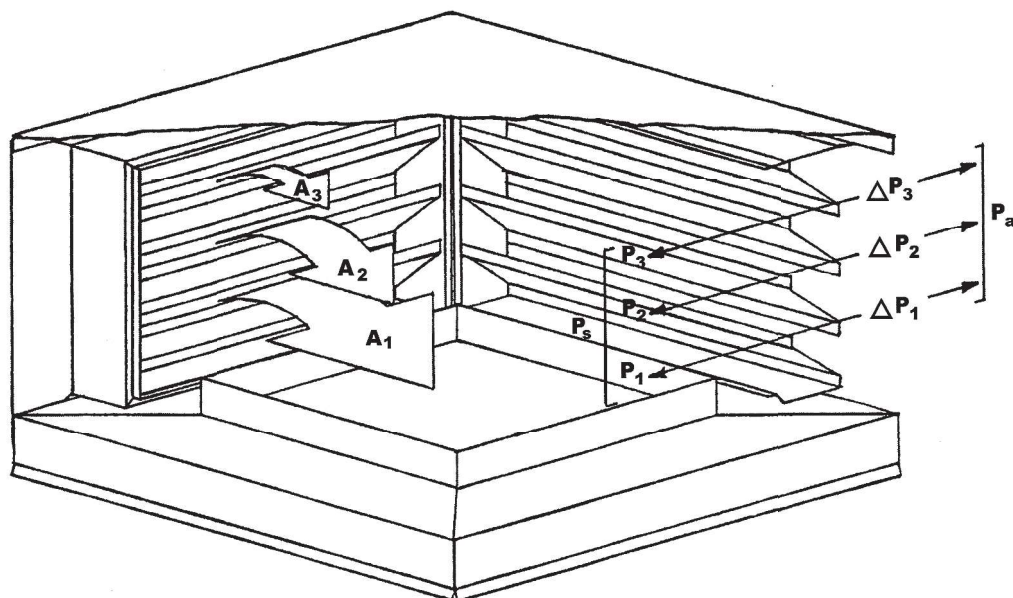

The atmospheric pressure (P_a) immediately surrounding a penthouse is virtually uniform. Inside a penthouse intaking air, static pressure (P_s) is lower than the atmospheric pressure outside.

$$P_s < P_a$$

Because of this pressure difference (ΔP), air is drawn into the penthouse. Inside the penthouse, static pressure is greater near the top than it is near the throat. This pressure difference forces air into the throat.

$$P_3 > P_2 > P_1$$

Since the atmospheric pressure outside is uniform, and the static pressure inside decreases toward the throat, the pressure difference (ΔP) between the outside and the inside decreases toward the throat.

$$P_a > P_3 > P_2 > P_1$$

$$\Delta P_1 > \Delta P_2 > \Delta P_3$$

As a result, there is greater air velocity, and thus greater air flow through the lower blade spaces than through the higher ones. This is true for all penthouses with equal blade spaces.

$$A_1 > A_2 > A_3$$

There is an implication for penthouse sizing. By capitalizing on the performance of lower blade spaces, a short, wide penthouse performs more efficiently than a tall, narrow penthouse with equal free area.

In this instance, superior performance carries an aesthetic dividend. A penthouse with a low profile blends more harmoniously with a level roof line than a high one does.

INSTALLATION DETAILS

PENTHOUSE - MULLION CORNER

MODEL : WPC5 - X

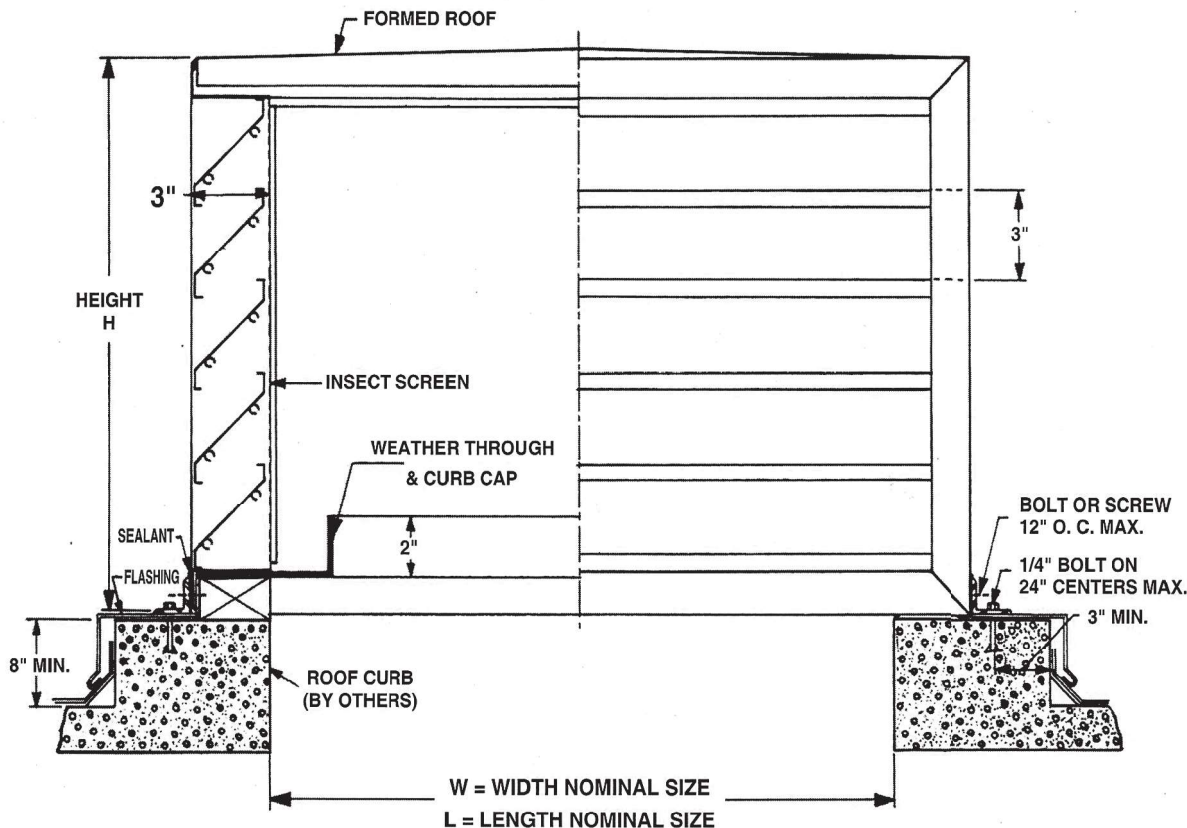

PENTHOUSE - MITERED CORNER

MODEL : WPH5 - X

